

C4 Calls

Bill Ackerman

31 August 2014

Date	Change
16 Oct 2008	Improve Set Your Pace .
05 Sep 2013	Add <ATC> the Class and Shove Off , mark Grand Spin/Fan the Top, Away, Dixie Hourglass , and Dixie Interlocked Diamond obsolete, clarify Split Cast and Quick Change , use the name Brace Thru .
23 Mar 2014	Fix <ATC> and Trade, Curli Wheel, Divvy Up and Spin Back , clarify Cloverleaf Turn
30 Apr 2014	Create change log.
3 May 2014	Clarify Wipe Out .
11 May 2014	Add In Style , note that Lock 'em Up is now C3B.
12 May 2014	Clarify Reciprocate .
18 May 2014	Add obsolete call Hinge and Circulate .
28 May 2014	Expand on Roll the Line / Wave .
30 May 2014	Add table of contents.
31 May 2014	Add obsolete call Swing Across .
1 Jun 2014	Put in a few internal hyperlinks.
4 Jul 2014	Many more hyperlinks.
9 Aug 2014	Improve hyperlinks among Mix the Line, Shuffle the Deck , and Single Shuffle .
31 Aug 2014	Explain Revert/Reflect , add Rotary Circulate and Pitch , fix Convert the Triangle .
5 Jun 2016	Cut out wasteful whitespace.

Copyright © 2004, 2005, 2008, 2012, 2013, 2014, William B. Ackerman. Permission is granted to make and redistribute non-commercial verbatim copies of this document.

Table of Contents

1 Formations and Terminology	2	[Cross] [Criss Cross] <N> Steps at a Time	13
Clumps	2	1/4 Wheel to a Diamond etc., 3/4 Wheel to a Diamond etc.	13
Traps	2	<anyone> Advance to a Column	14
1/4 Box	3	<anyone> Bypass	14
Spindle or Sausage	3	<anyone> Cross	14
Bat or Rigger	3	<ATC> and Spin <direction>, <ATC> and Spin <anything>	15
Space Invader	3	<ATC> Back	16
Breathing	3	<ATC> er's Dream/Nightmare	16
Inner Active, Outer Active	3	3/4 <ATC> and Trade	17
2 Preliminaries	4	<ATC> Back and Dodge, <ATC> and Dodge	17
Natural	4	<ATC> the Class	17
Cross Over Circulate	4	<ATC> er's Flow [but Cross it] [but Criss Cross it]	18
Quarter To Handhold	5	<ATC> Eroo	19
Revert and Reflect	5	<ATC> to a Diamond / Interlocked Diamond, Hourglass, Z	19
3 New Taggers	6	<ATC> Your [Cross] [Criss Cross] Neighbor	20
Double Pass	6	<ATC> the Yellow Brick Road, <ATC> the Yellow Bricking <anything>	20
Track	6	<anything> and 1/4 More	20
Invert	7	<anything> and Anything	21
Pass and Roll	8	<anything> the Action	21
Extend	8	<anything> the Boat	21
Jay Walk	8	<anything> the Key	21
4 The "but" Convention	10	<anything> the Lock, <anything> the Top, <anything> the Hinge	22
5 The Calls	11	<anything> the Wave	22
<N/4> the Alter	11	3x1 Flip/Cut Diamond	22
<I-J-K> Quarter the Alter	11	About	22
<N/4> the Alter and Circulate	11	All 8 Cross Cycle	23
<I-J-K> Quarter the Alter and Circulate	12	All 8 Cycle and Wheel, All 8 Cycle and Turn and Deal	23
<N/4> Chain and Circulate In	12	Alter the Diamond	23
1/4 Cross, 3/4 Cross	12	An Anchor, <anything> An Anchor, An Anchor but <anything>	23
<I-J-K-L> Change the Web	12		
<I-J-K-L> Quarter the Deucey	13		
<I-J-K-L> Relay the Top	13		

Anchor <N/4>	24	Clear the Centers for <anything>, Clear the Centers but Cross It for <anything>	40
Area Code	24	Clear the Way, Clear the Way but Cross It	41
Away	24	Clover Flow	41
Bail Out	24	Cross Cloverleaf	42
Barge the Action	24	[Cross] Clover the Horn	42
Barge Thru	25	Clover the Wave, <anything> the Wave	42
Barrel of Fun	25	Cloverleaf Turn, Cloverleaf Turn Reaction, Cloverleaf Turn Reactivate, Cloverleaf Turn Nuclear Reaction	43
Beau Tie, Belle Tie	25	Collapse	43
Beep Beep	25	Complete the Tag	43
Bias Trade Circulate	25	Connect the Diamond	44
Bits and Pieces	26	Continue to [Magic] [Cross] Invert	44
Brace Yourself	27	Contour the Line	45
<anyone> Break the Alamo	27	Convert the Triangle	45
Bridge the Gap	28	Cooperate	46
Bring Us Together	30	Coordinate to a Diamond	46
Buckle and <anything>	31	Counteract	46
By [By] [By]	32	[Cross] Counterpoint	47
Cast a Net	32	Countershake	48
Cast an Anchor	33	Cover Up	48
Cast Away	33	Crackle	49
Centers Cut Out	33	Create a Column	49
Centers Out, or Put Centers Out	33	Create a Diamond	49
Centers Thru and Close the Gate, or Put Centers Thru and Close the Gate	34	Criss Cross the Diamond	49
Change Jays	34	Cross and Divide	50
Change Lanes	35	Cross Breed Thru	50
[Reverse] Change-O	36	Cross Cycle	51
Change the Apex	36	Cross Drop <direction>	51
Change the Web	36	Cross Follow Thru	52
Chase the Tag <N/4>	37	Cross Horseshoe Turn	52
Cheerio	37	Cross Linear Cycle	52
Chip Off	38	Cross Sashay	52
Circle to a 2-Faced Line	38	Cross Scoot and Weave	53
Circle <N/4> to a Wave	39	Cross the Ocean	53
Circle the Tag <N/4>	39		
Clean Sweep <N/4>	39		
Clear Out, <anything> Clear Out	40		

Cross the Top	53	Easy Does It	68
Cross to a Diamond, Hourglass etc.	53	Eight Roll Away with a Half Sashay	68
Cross to a Wave	54	Ends Cut In	68
Cross Town Roll	55	E.R.A.	69
Cross Walk and Dodge	56	Erase	69
Curl Apart	56	Explode the [Cross] Clover	69
<i>Curl Thru</i>	56	Explosion	69
Curlique	56	Face the Music	70
Curli Cross	56	Fall Into a Column	70
Curli Cross the Top	56	Fan and Cross Thru	70
Curli Wheel	57	Fan Back	71
Curli Pass	57	Fan Chain and Circulate In	71
<anyone> Curve <direction>	57	Fan Chain and Circulate the Gears	71
Cut Across	58	Fan the Gate, Fan the Gating <any- thing>	71
[Reverse] Cut the <formation>	58	Fan Thru, Fan and Cross Thru	72
Cycle and <anything>	59	Ferris Trade and Wheel	72
[Cross] Cy-Kick	59	<i>Fiddle Around</i>	73
Derby	59	<anyone> Finish the Stack	73
<i>Detach</i>	60	First Choice, First <anything>	73
Detract <N>, Detract <anything>	60	Flare the Star	74
Deuces Wild	60	[Reverse] Flip the <formation>	74
Diamond Inlet, Diamond Outlet	61	Flowing <anything>	75
Diamond Recycle	61	<i>Fly Away, Fly Away and <anything></i>	75
Divide	62	Follow and Cross, Follow and Criss Cross	76
<i>Divide and Pair</i>	62	Follow the Yellow Brick Road, Fol- low the Yellow Bricking <anything>	76
Divvy Up	62	[Cross] [Criss Cross] Follow to a Di- amond	77
Dixie Chain	63	Follow to an Interlocked Diamond, Hourglass etc.	77
Dixie Daisy	63	Go First Class	77
Dixie Derby, Derby	64	Grand Cross Roll	78
<i>Dixie Hourglass, Dixie Interlocked Diamond</i>	64	Grand Linear Cycle	79
Dixie Spin	65	Grand Run Wild	79
[Cross] Double Down	65	<i>Grand Spin the Top, Grand Fan the Top</i>	79
Double the Wave	66	Grand Switch	80
[Cross] [Criss Cross] Double Your Pleasure	66		
Dream	67		
<i>Drift Around</i>	68		

<i>Grand Walk and Dodge</i>	80	<i>Lines Walk <direction></i>	92
<i>Gravitate</i>	80	<i>[Cross] Lock 'em Up</i>	92
<i>Hammerlane</i>	81	<i>Long Trip</i>	93
<i>Hang a Right/Left</i>	81	<i>Magic In Roll Circulate, Out Roll Circulate, Zoom Roll Circulate, Here Comes the Judge, Sock it to Me</i> . .	93
<i>Hang Loose</i>	81	<i>[Cross] Make a Pass, [Cross] Make a Pass but <anything></i>	94
<i>Here Comes the Diamond, Here Comes the Wave</i>	82	<i><anyone> Mark Time, Mark Time</i>	95
<i>Hinge and Circulate <direction></i> .	82	<i>Mayday <direction></i>	96
<i>Hinge and Trade</i>	82	<i>M.C.P.</i>	97
<i>Hinge By <M/4> x <N/4> x ...</i> . .	83	<i>Mesh</i>	97
<i>Hinge the Top, Hinge the Lock</i> . .	83	<i>[Cross] Mini Pleasure</i>	97
<i>Hit the Wall</i>	84	<i><anyone> Mix and Mingle</i>	98
<i>Hoop-De-Do</i>	84	<i>Mix the Deal</i>	98
<i>[Cross] <anyone> Hop</i>	84	<i>Mix the Deucey</i>	98
<i>Hot Foot Spin</i>	84	<i>Mix the Turn and Deal</i>	98
<i>Hourglass Inlet, Hourglass Outlet</i>	84	<i>Mix the Line</i>	98
<i>In Roll to a Diamond, Out Roll to a Diamond, Zoom Roll to a Diamond, Here Comes the Diamond, Sock it to the Diamond</i>	85	<i>Mixed Up Square Thru, Mixed Up <anything></i>	99
<i>In Roll to a Wave, Out Roll to a Wave, Zoom Roll to a Wave, Here Comes the Wave, Sock it to the Wave</i>	86	<i>Nice and Easy</i>	99
<i>Inner Code</i>	87	<i>Nicely</i>	100
<i>In Style</i>	87	<i>Nightmare</i>	100
<i>Interlocked Scoot Chain Thru</i> . . .	88	<i>Nip and Tuck</i>	100
<i>Isolate</i>	88	<i>Open Ups <anything></i>	100
<i>Jam Thru</i>	88	<i>[Left] [Twin] Orbit Circulate</i>	101
<i><anyone> Kick By <N></i>	89	<i>Out Roll to a Diamond, Out Roll to a Wave</i>	101
<i>Kick the Habit</i>	89	<i>Outer Code</i>	101
<i>Lead the Class</i>	89	<i>Outpost</i>	102
<i>Lead the Way</i>	90	<i>[Cross] Pair the Line</i>	102
<i>Left and Right Thru</i>	90	<i>Pass and Roll the Axle</i>	103
<i>Left On</i>	90	<i>Pass and Roll the Yellow Brick Road</i>	104
<i>Lift Off but <anything></i>	90	<i>Pass and Roll the Yellow Bricking <anything></i>	104
<i>Like a Rigger</i>	91	<i>Pass and Roll Your [Cross] [Criss Cross] Neighbor</i>	104
<i>Linear Action but Cross it</i>	91	<i>Pass the Top</i>	104
<i>Linear Flow [but Cross it] [but Criss Cross it]</i>	91	<i>Pass to the Outside</i>	105

Peel the Deal, Trail the Deal, etc.	105	Roll Out to a Column	120
Peel the Wave, Trail the Wave	106	<i>Roll the Line</i>	121
<anyone> PinWheel	106	Roll the Wave	122
Pitch <direction>	106	Rotary Circulate	122
Plus <N>	106	Round and Cross	123
Pop	107	Round Off	123
Press for Time	107	Round the Horn	123
Presto	108	[Cross] Run Away	124
Push Off	108	<anyone> Run By <N>	124
Push Open the Gate	109	<anyone> [Cross] Run the Top	124
Quick Change	110	<anyone> Run the Wheel	125
Quick Wrap	110	Run Wild	126
[Cross] Reactivate to a Diamond, Coordinate to a Diamond	110	Sashay Thru	126
Reciprocate	111	Scamper	127
Recount	111	Scatter Follow to a Diamond, Scatter <anything>	127
Relay the Diamond	112	[Cross] [Criss Cross] Scoot Apart	127
<i>Relay the Yoyo</i>	113	Scoot the Triangle	128
Relay Your Pleasure	113	Set Back	128
Remember the Alamo	113	Set Your Pace	129
[Cross] Replace the Column [but <any- thing>]	114	Sets in Motion Plus 1 or 2	130
Retreat the Line	115	Settle Back	130
Reverse Explode	115	Shadow Box <anything>, Shadow <formation> <anything>	132
<i>Reverse Stack the Line</i>	115	[Criss Cross] Shadow the Column	132
Reverse the Diamond	116	[Cross] [Criss Cross] Shadow to a Diamond	133
Ride the Tide	116	Ship Ahoy	133
Right/Left Anchor <N/4>	117	Short and Sweet	134
Right and Left By [By] [By]	117	Short Cut	134
Right and Left Roll	118	Short Cycle	134
Right On <N>, Left On <N>, Right/Left On <N> and <M/4>	118	Short Trip	135
Right Roll The	118	Shove Off	135
Rip Saw	119	Shuffle and Wheel	136
Rip the Line	119	Shuffle the Deck	136
Roll Em	119	Shuttle <direction>, Shuttle <any- thing>	136
Rolling <anything>	120	Siamese Breakdown	137
Roll Out the Barrel	120		

Single Hinge and Trade	138	Stack the Wheel	148
<i>Single Hinge and Circulate <direction></i>	138	Star to a Wave	148
Single Scoot and Trade	138	Step and <anything>	149
Single Shuffle	139	Step Lively	149
Slim Down	139	[Cross] Straight Away [but <anything>]	149
Snag Circulate	140	Straight Fire	150
Snake	140	Strike Out	151
Snap	140	Stroll and Cycle, Stroll <anything>	151
Snap, Crackle, and Pop	141	Stroll Down the Lane	152
<i>Snap Back</i>	141	[Reverse] [Cross] Swap the Windmill	152
Snap the Diamond	141	Substitute	153
Snap the Tag <N/4>	141	Swat the Flea	153
Sock it to the Diamond, Sock it to the Wave	142	Sweeping <anything>	153
Soft Touch, Soft <anything>	142	Swing About	153
Spin a Wheel	143	<anyone> <i>Swing Across</i>	154
Spin Back, Fan Back	143	<i>Swing and Cross</i>	154
Spin Chain and Anything	144	<i>Swing Back</i>	154
Spin Chain and Circulate In, Fan Chain and Circulate In	144	Swing Chain Thru, etc.	154
Spin Chain and Circulate the Gears, Fan Chain and Circulate the Gears	144	Swing to a Column	155
Spin Chain the Star	144	<i>Switch Back</i>	155
Spin Tag the Deucey [<direction>]	145	<i>Switcheroo</i>	155
<i>Spin the Yoyo</i>	145	<anyone> [Cross] Swivel	155
Splash <direction>, Splash <anything>	145	Tag Circulate	156
Split and Cross	146	Tag the Star <N/4>	156
Split Cast, Split Cast <N/4>	146	Tap the <anyone>	156
<i>Split Ping-Pong Circulate</i>	147	Teacup Like a Daisy Chain	157
Split the Difference	147	The Action	157
Square Out	147	The Difference, Split the Difference, <anything> the Difference	158
Square the Barge, Square the Barge <N/4>	147	The Plank	159
Square the Barge the Action, Square the Barge <N/4> the Action	148	Tickle	159
Square The Bases Plus 2	148	[Cross] <anyone> Tie	159
Square Turn Thru <N>	148	<i>Tip Toe, Tip Toe Thru the Tulips</i>	160
		Touch and Go <M/4> x <N/4>, Touch and Go <M/4> x <anything>, etc.	160
		Touch of Class	160
		Touch Tone <M/4> x <N/4>	161

Tow Truck	161	Who's On First	176
Track <N>	161	Wipe Out	176
Track and Trade, Track and <any- thing>	162	With Finesse	177
[Cross] Trade Your Neighbor [<di- rection>]	162	With Magnetism	177
Trail and Peel	162	You All	177
Trail Chain Thru	163	<anyone> Zing <N>	178
Trail The Top, Trail <anything>	163	Zip the Top	178
Transaction, Transactivate, Trans <anything>	164	<anyone> Zoom <N>	178
Trim the Web	164	Zoom Roll Circulate	179
Triple Cast	165	Zoom Roll to a Diamond, Zoom Roll to a Wave	179
Triple Play <anything>	165		
Triple Turn, Triple Wheel	166		
Trixie, Trixie Spin	166		
Tunnel <direction>, Tunnel <any- thing>, Tunnel Thru	167		
<i>Turn and Flip</i>	168		
Turn and Left Thru	168		
Turn and Q, Split Turn and Q	168		
Turn and Weave	169		
Turn Away	170		
Turn By	171		
Turn On	172		
Turnover	172		
Turntable	172		
Veer and Turn <M/4> x <N/4>	173		
Veering <anything>	173		
Vertical Turn and Deal	173		
Walk Out to a Column	173		
Walk the [Cross] Clover	174		
Walk the Plank, <anything> the Plank	174		
Wheel Fan and Cross Thru	175		
Wheel to a Diamond / Interlocked Diamond, Hourglass, Z	175		
Wheel to a Line	175		
[Cross] [Criss Cross] Wind the Bob- bin	176		

This is the first of three books about C4. The first covers calls, the second covers concepts, and the third covers miscellaneous “notions”.

It is not my intention to be definitive or encyclopedic about just what is on the C4 “list”. When in doubt, I have attempted to err on the side of inclusiveness. However, I have omitted calls that are clearly no longer in serious use.

Some calls are nevertheless sufficiently obscure that one might question the usefulness of including them, particularly for people learning C4. I have listed their names in italics while the “mainstream” C4 calls are in bold face. Whether I have judged wisely is open to debate.

These books contain many examples. They are sometimes intentionally very difficult. For example, in the descriptions of concepts, the example calls are sometimes very complex, for the purpose of showing that the working of the concept is independent of the complexity of the underlying call. In any case, the examples are intended as manual or mental checker-pushing exercises. Don’t bother checking them by computer—they work.

Chapter 1

Formations and Terminology

Clumps

This is a commonly-used term to denote a 4x4 matrix occupied as 2x2 boxes in the corners. Facing directions are irrelevant.

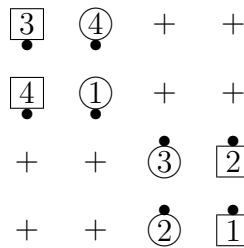

clumps

Traps

This is short for “trapezoids” and denotes a 2x8 matrix in which each 2x4 has the live people in a trapezoid. Facing directions are irrelevant.

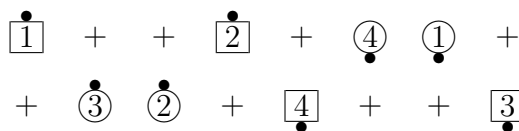

traps

1/4 Box

This is analogous to a 1/4 tag or 1/4 line. It is the “Heads Touch 1/4” setup. A 3/4 box is the same thing with the outside facing out as a couple.

Spindle or Sausage

These are names for the setup obtained by doing a 1/2 Circulate from columns. Facing directions are irrelevant.

Bat or Rigger

These are names for the setup obtained by having the ends Hinge from columns. Facing directions are irrelevant. It is the usual setup for the Rigger concept.

Space Invader

This is a call that does not involve any “breathing” or adjusting of one’s final position based on the formation. Everyone’s motion is described in absolute terms. The fundamental example of such a call is Press.

Breathing

This is the act of moving multiple resultant formations toward or away from each other so that they will abut properly at the end of the call. While much has been written about esoteric and theoretical aspects of this, it is really very simple. It is the thing that Mainstream dancers know how to do after a Spin the Top.

Inner Active, Outer Active

This is a designation used in this book, and occasionally in Challenge dancing at large, to designate specific people in waves. The inner actives are the end of the wave looking in and her partner. The outer actives are the end of the wave looking out and her partner. These terms derive from a rather obscure and obsolete concept.

Chapter 2

Preliminaries

Natural

Natural is used in this book to mean “any shoulder” or “any hand”. From a left-handed miniwave, a Natural Step Thru, Pass Thru, or Turn Thru is a Left Step Thru, Pass Thru, or Turn Thru. From a left-handed 2-faced line, a Natural 1/2 Tag is a Left 1/2 Tag. Hence, a Couples Twosome Hinge could be thought of as a Natural 1/2 Tag.

Cross Over Circulate

Definitions that involve Cross Over Circulate sometimes require one to do it from columns. This is a Circulate and cross into the other column. It arises in such things as [Reverse] Change-O, Trade the Deucey from a starting DPT, or Change Lanes from a 3/4 box.

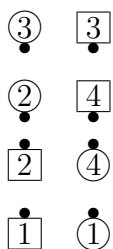

before Trade the Deucey

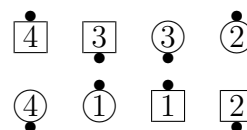

after

If the #1 person in a column is asked to Cross Over Circulate, the action is a normal Circulate and then cross over, which is just a U-Turn Back. Some people consider this less than totally esthetic, but it does get used in some definitions.

Quarter To Handhold

This term is typically used in a 3/4 tag, after an extend. It means 1/4 in the direction of the miniwave from which you extended. (Replacing the extend with 1/2 Box Circulate would get the same effect.)

Revert and Reflect

These are terms used with compound tagging calls, as in “Reflected Loop and Tag Chain Thru Reaction”. They are described in Book 2: <http://www.challengedance.org/sd/book2.pdf>.

Briefly, these actions are performed when the tagging call reaches the half-tag point. For Revert, all Cast 3/4. For Reflect, all Counter Rotate 1/4, in the tagging formation (typically a 2x2 box). Then continue with the tagging suffix.

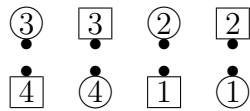

before Reflected Circle the Tag
Chain Thru Reaction

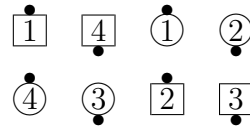

after

Chapter 3

New Taggers

A number of new taggers appear at high challenge, that are really nothing but new interpretations of existing calls. They are often so simple that they are not actually used explicitly as calls, but are used as ways of using the simple action with more complex tagging endings.

Remember that whenever any tagger is used in any kind of Reaction/Reactivate/Nuclear Reaction context, it is always an <ATC> **back** Reaction. There is always a trade in the middle. A caller might say “Track Reaction”, but it always means “Track Back Reaction”.

Double Pass

This is incredibly simple. It takes the Mainstream call Double Pass Thru and makes a tagger out of it. From a starting DPT, you are at the 0-tag position. One would not say Double Pass the Tag 3/4, but might use it in calls like Reflected Double Pass Chain Thru Reactivate.



before Double Pass Your
Criss Cross Neighbor

after

Track

This is equally obvious.

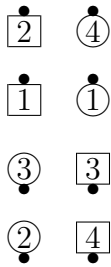

before Revert Track and Scatter Nuclear Reaction

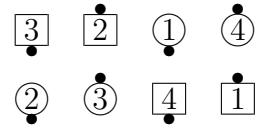

after

Invert

Invert the Column 1/2, and you are at the 1/2 tag position. This can be quite confusing, because Invert the Column and Invert the Tag both take fractions, and those fractions have very similar meanings.

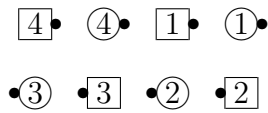

before Invert the Column 3/4

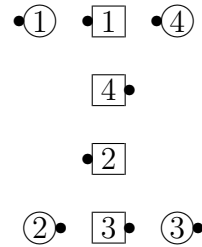

after

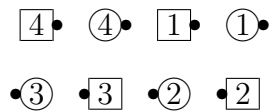

before Invert the Tag 3/4

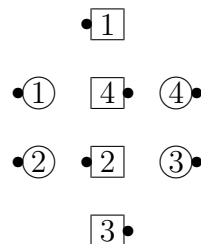

after

Of course, the phrase “Invert the Tag” is almost never used, because these special taggers are generally used only with interesting endings. So “Invert 3/4” means “Invert the Column 3/4”, while

“Invert Chain Thru” and “Invert Your Leader” refer to the tagger.

Pass and Roll

Think about Pass and Roll Your Neighbor. This is most commonly used in the form Pass and Roll Your Cross Neighbor or Pass and Roll Your Criss Cross Neighbor.

Extend

Some tagging endings naturally start from a 3/4 tag, and could start with an extend from waves.

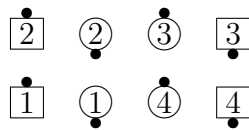

before Extender's Delight

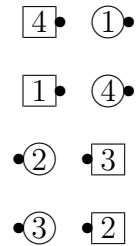

after

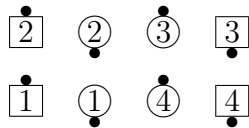

before Extend and Spin

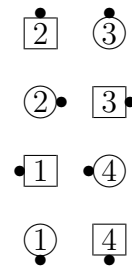

after

Jay Walk

The same is true of Jay Walk.

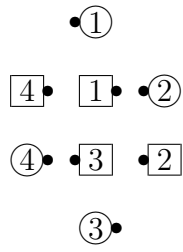

before Jay Walker's Dilemma

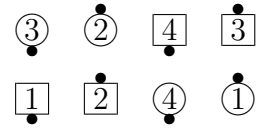

after

Chapter 4

The “but” Convention

There are many calls that can be modified by “but <anything>” without further explanation. (Calls can also be modified with an explicit specification of what part is replaced, as in “Stampede but replace Trade the Wave with Cut the Diamond”. Those are simple—just do what the caller says.)

For a number of these calls, one has to memorize, on a case-by-case basis, what to do. For example, on Lift Off but <anything>, the final Couples Circulate is replaced. On Line to Line but <anything> or Chisel Thru but <anything>, the final Pass In is replaced.

However, a large number of calls that take “but” modifiers follow this simple convention: the last thing that is done in the center is the thing that is replaced. Well-known examples of this are Chain Reaction, Tally Ho, and Cover Up. Less well-known examples are Link Up, Load the Boat, Square the Bases, Walk the Clover, and Make a Pass. On Percolate but <anything>, the final Hinge and Cross is replaced.

Chapter 5

The Calls

<N/4> the Alter

This is sort of like Alter the Wave, with the given fraction ($1/4$ or $3/4$) used everywhere.

Turn the indicated fraction. Then the centers turn that fraction while the ends U-Turn Back. Counter Rotate the diamond (“Turn the star”) by the indicated amount. Flip the Diamond.

This has 4 parts, a fact which is exploited frequently.

<I-J-K> Quarter the Alter

There are 3 different places where fractions can be used in Quarter the Alter. The fractions can be given individually.

Turn the first fraction. Then the centers turn the second fraction while the ends U-Turn Back. Counter Rotate the diamond (“Turn the star”) by the the third fraction. Flip the Diamond.

This may be called just <I-J-K> the Alter.

<N/4> the Alter and Circulate

This is sort of like Alter and Circulate, with the given fraction ($1/4$ or $3/4$) used everywhere.

Turn the indicated fraction. Then the centers turn that fraction while the ends U-Turn Back. Ends Circulate while the center 2 trade. Counter Rotate the diamond (“Turn the star”) by the indicated amount. Flip the Diamond.

<I-J-K> Quarter the Alter and Circulate

Turn the first fraction. Then the centers turn the second fraction while the ends U-Turn Back. Ends Circulate while the center 2 trade. Counter Rotate the diamond (“Turn the star”) by the the third fraction. Flip the Diamond.

This may be called just <I-J-K> Alter and Circulate.

<N/4> Chain and Circulate In

This is closely related to Spin Chain and Circulate In. In fact, 3/4 Chain and Circulate In is the same as Fan Chain and Circulate In.

Ends: Circulate and then Cross Over Circulate.

Centers: Cast the indicated fraction, which should leave them in a line. The center 2 then trade, then cast off 3/4 (always), and Spread to let the others come into the center on their Cross Over Circulate.

The starting setup is typically lines if the fraction is odd, and diamonds if it is even.

The two groups of people should finish at about the same time, so ideally things should go smoothly. But just in case, it is wise for then ends to think in terms of two circulates, figure out who is going to be spreading outward, and then spread inward in a way that neither knocks them down nor confuses them.

When done from T-bones, the same considerations apply as for Change Lanes.

Because dancers often start doing a trade as soon as they hear “Spin Chain”, and because this sounds similar, an extremely common mistake is to start this with a trade. Good dancers go out of their way to be careful about this. The sound effect is “It starts in the center”.

1/4 Cross, 3/4 Cross

This is 2/3 of a <N/4> Mix. Arm Turn the indicated fraction, and the centers Cross Run. This is a right-hand call.

<I-J-K-L> Change the Web

This is like Change the web, but the fractions are given separately.

The center wave casts the first fraction, and then the center two cast the second fraction. After making the stars, they turn the third fraction. The center 2 finish by casting the fourth fraction.

<I-J-K-L> Quarter the Deucey

This is like 1/4 the Deucey or 3/4 the Deucey, but the fractions are given separately.

Cast the first fraction. Centers Cast the second fraction. The end looking out Circulates, while the end looking in steps forward into a star. The center star turns the third fraction. Finally those who meet cast the last fraction while the others “move up”.

<I-J-K-L> Relay the Top

This is like Relay the Top or <N/4> cast and Relay, but the fractions are given separately.

Cast the first fraction. Centers cast the second fraction while the ends half Circulate. Turn the center star the third fraction, while the others trade. Finally, those who meet cast the last fraction while the others “move up”.

[Cross] [Criss Cross] <N> Steps at a Time

These are generalizations of <N> Steps at a Time. On Cross <N> Steps at a Time, the first <N> people Trail Off instead of Peeling Off, and then Bend the Line, while the others move forward, Trade, and Roll. In Criss Cross <N> Steps at a Time, in addition the first <N> people Trailing Off, the others cross as they come in to the middle, Trade with their opposite hand, and Roll.

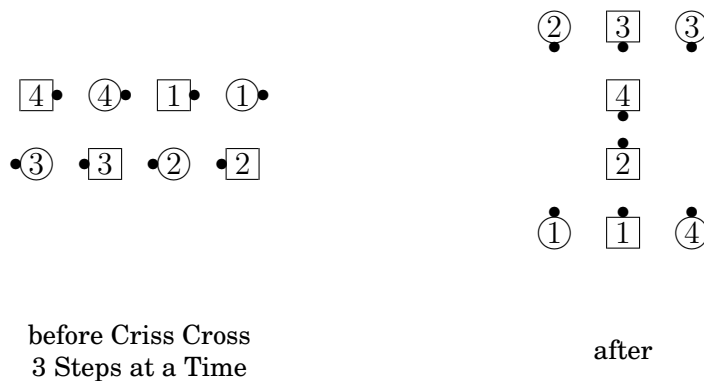

1/4 Wheel to a Diamond etc., 3/4 Wheel to a Diamond etc.

These are like Wheel to a Diamond etc., but they start like a 1/4 Wheel the Ocean or 3/4 Wheel the Ocean.

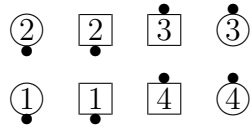

before 1/4 Wheel to an Hourglass

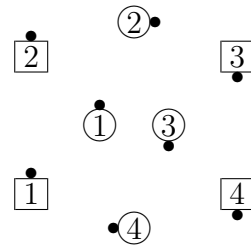

after

<anyone> Advance to a Column

This starts with <anyone> Walk while the others Dodge. The setup should now be a column. Do a Column Circulate, centers trade, and Column Circulate.

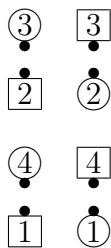

before Beaus Advance to a Column

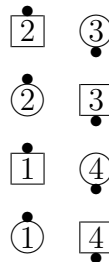

after first part

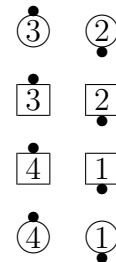

finished

One can also “Finish Advance to a Column”. This omits the Walk and Dodge. The person designator is not given.

<anyone> Bypass

All Pass Thru, and the designated people **refrain from** turning around. The non-designees U-Turn Back.

<anyone> Cross

The designated people pull by on the diagonal, the same as on the Advanced call <anything> and Cross.

<ATC> and Spin <direction>, <ATC> and Spin <anything>

This is a general tagging ending, subject to all the usual [revert/reflect stuff](#), page 5.

Tag to the 3/4 position. Centers cast off 3/4, while the ends quarter in the indicated direction. If no direction is given, the ends do not turn.

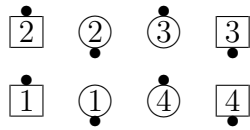

before Flip and
Spin Left

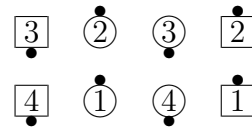

after

The caller may give a call instead of a direction, in which case the ends do the call.

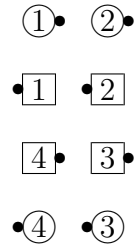

before Flip and
Spin [Rally]

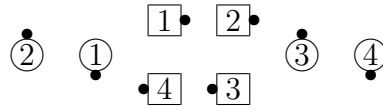

after

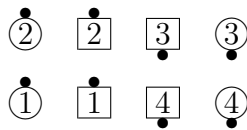

before Tag and
Spin [Concentric Shakedown]

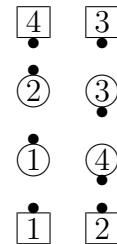

after

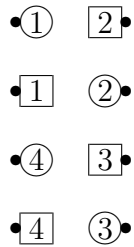

before Vertical Tag and Spin [Single Wheel]

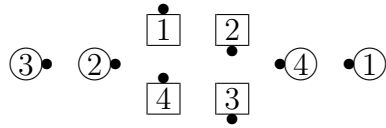

after

<ATC> Back

This is the same as the C1 call “<ATC> Back to a Wave”. Sometimes callers say “to a Wave”, and sometimes they don’t.

This is a general tagging ending, subject to all the usual [revert/reflect stuff](#), page 5.

Tag to the 1/2 position. Scoot Back.

<ATC> er’s Dream/Nightmare

These are general tagging endings, subject to all the usual [revert/reflect stuff](#), page 5. They are rather like <ATC> er’s Delight/Dilemma.

Tag to the 3/4 position. Ends quarter right for Dream and left for Nightmare, and circulate *just one position*. The centers Swing, Slip, and Slide Thru. The Slide Thru will be out of a mini-wave. Beware: in some cases (e.g. Flipper’s Dream from a left-handed wave) the Slide Thru will be from a left-handed mini-wave. Purists may consider that bogus. Do it anyway. Step ahead from the left-handed mini-wave and quarter in the appropriate direction. Do not do a Mirror Slide Thru.

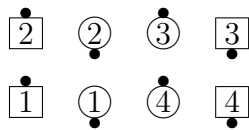

before Flipper’s Dream

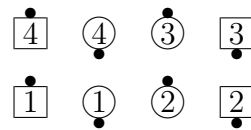

after

Delight/Dilemma/Dream/Nightmare can be called by themselves from a 3/4 tag or other applicable setup. One also hears Central Delight, etc.

3/4 <ATC> and Trade

This is a general tagging ending, subject to all the usual [revert/reflect stuff](#), page 5.

Tag to the 3/4 position. Centers Trade the Wave while the ends trade.

Because the phrase “and trade” can be misconstrued so easily, this is a linguistically dangerous call. Saying just “Tag and Trade” would have the dancers wondering what alternative parsings exist. So the caller will generally put the phrase “3/4” in it somewhere, as in “3/4 Flip and Trade” or “Vertical Tag 3/4 and Trade”. (Of course, putting “3/4” in front of a call runs the risk of making dancers think it is being fractionalized, so it’s still linguistically dangerous. There’s only so much the caller can do.)

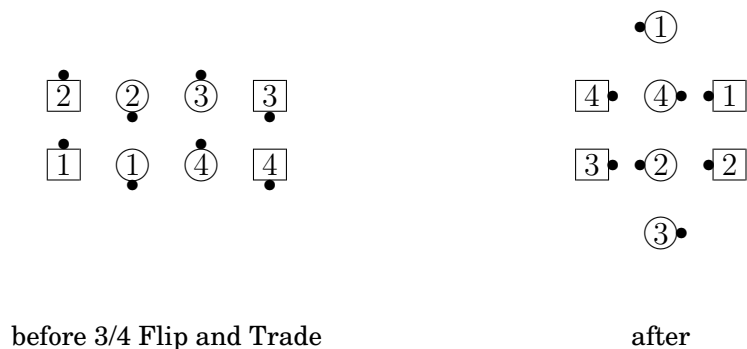

<ATC> Back and Dodge, <ATC> and Dodge

This is a general tagging ending, subject to all the usual [revert/reflect stuff](#), page 5.

It is like <ATC> Back to a Wave, but turns the Scoot Back into a Scoot and Dodge. On the call <ATC> Chain Thru and Dodge, it’s a Scoot Chain Thru and Dodge. There is **always** a Scoot Back, just as there is always a Scoot Back on things like Flip Reaction. The caller might leave out the word “back”. “Flip and Dodge” is the same as “Flip Back and Dodge”.

It is considered unamusing to use “Scatter” with this, as in “Flip Chain Thru and Scatter and Dodge” or “Scatter Scoot and Dodge”. In this case, the people doing the Dodge slide past each other into each other’s place.

The “to a Wave” variant is also unamusing.

<ATC> the Class

These are general tagging endings, subject to all the usual [revert/reflect stuff](#), page 5.

Tag to the 1/2 position, and Lead the Class: Leads do a Follow Your Leader. Trailers Extend, Recycle, Plus 2, and face back into the center. Finishes in a DPT.

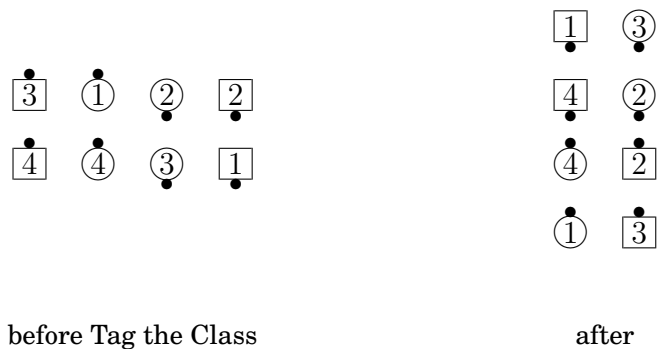

<ATC> er's Flow [but Cross it] [but Criss Cross it]

These are general tagging endings, subject to all the usual [revert/reflect stuff](#), page 5.

Tag to the 1/2 position. What happens next can be formulated in a number of ways, but the commonly used method is:

- <ATC> er's Flow: Tandem trade
- <ATC> er's Flow but Cross it: Tandem Cross Roll
- <ATC> er's Flow but Criss Cross it: Tandem Trade the Wave

Then, in all 3 cases, do a (normal, not tandem) Slip.

This derives from Linear Flow, which see.

These calls may have been originally intended to be given with "Cross" and "Criss Cross" modifiers in front, as in "Cross Tagger's Flow", but it leads to serious ambiguity if the tagging call is "Flip" or "Loop and Tag". So the "Cross" and "Criss Cross" modifiers are always at the end, as in "Flipper's Flow but Cross it" or "Cross Loop and Tagger's Flow but Criss Cross it".

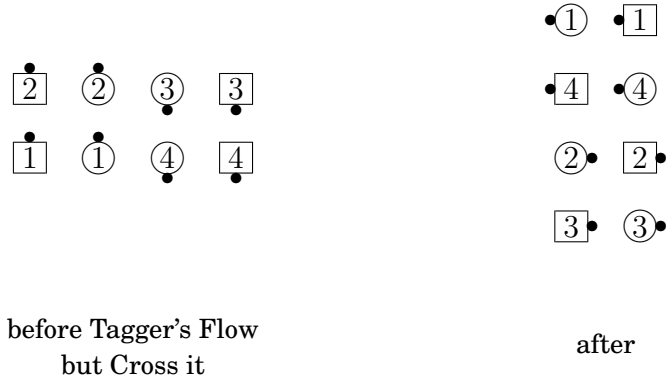

<ATC> Eroo

This is a general tagging ending, subject to all the usual [revert/reflect stuff](#), page 5.

Tag to the 3/4 position. Ends Quarter to Handhold (typically right) and circulate one position while the centers cast off 3/4.

Sometimes “Eroo” is called by itself when in diamonds. Ends circulate while the centers cast off 3/4.

“Switcheroo” – Switch to a Diamond, Eroo.

<ATC> to a Diamond / Interlocked Diamond, Hourglass, Z

These are general tagging endings, subject to all the usual [revert/reflect stuff](#), page 5.

Tag to the 3/4 position. Ends quarter to wave direction. This is “<ATC> to a diamond”. For the other setups, do the same transformation as you would on “Switch to a <whatever>”: Center 2 Slither for interlocked diamonds, center 2 Snake for an hourglass, or ends roll and adjust to stand behind the appropriate center for a Z.

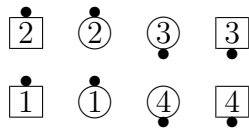

before Tag to an Hourglass

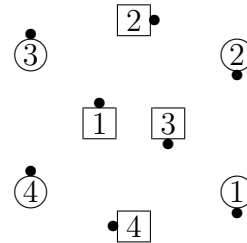

after

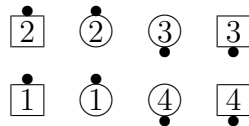

before Tag to a Z

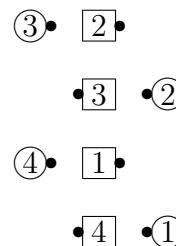

after

These variants for interlocked diamond, hourglass, or Z also apply to other calls that create diamonds: “Inlet to a <whatever>”, “Follow to a <whatever>”, “Cross to a <whatever>”, or “Wheel to

a <whatever>”. The adjustment to the final formation is always the same. The tricky one is for an hourglass—the center 2 do a Snake (in one smooth and elegant motion, of course) as they come into the center.

<ATC> Your [Cross] [Criss Cross] Neighbor

These are general tagging endings, subject to all the usual [revert/reflect stuff](#), page 5.

These are just the Cross and Criss Cross variants of “<ATC> Your Neighbor.” Unlike some of the other tagging endings, there is no linguistic ambiguity here—the “Cross” or “Criss Cross” is placed after the tagging call. For example, “Cross Flip Your Cross Neighbor.”

<ATC> the Yellow Brick Road, <ATC> the Yellow Bricking <anything>

These are general tagging endings, subject to all the usual [revert/reflect stuff](#), page 5.

These are the <ATC> versions of “Follow the Yellow Brick Road”: Tag to the 1/2 position, Follow Your Neighbor, Spread, Slither, centers Follow Your Neighbor and Spread while the ends circulate 1-1/2, then the couple on the end of the line of 6 Concentric Wheel and Deal while the other outside person counter rotate to become the end of the center wave.

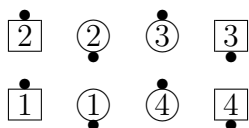

before Reflected Cross
Loop and Tag the Yellow
Bricking [Bend the Line]

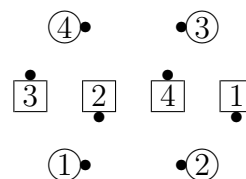

after

Calls such as the example above tax one’s memory. Be prepared to help your fellow dancers if they forget the <anything> call.

<anything> and 1/4 More

This is done after a call that ends with a Courtesy Turn. Turn as a couple 1/4 more (to the left).

<anything> and Anything

The words “and Anything” (yes, literally those words) after a call that finishes with the centers Casting Off 3/4, has them instead Cast Off only 1/4, while the ends U-Turn Back. Some examples are:

- Relay the Top and Anything
- Chain Reaction and Anything
- Spin Chain and Anything (meaning Spin Chain Thru and Anything)
- Diamond Chain and Anything (meaning Diamond Chain Thru and Anything)

<anything> the Action

Do <anything>, followed by The Action.

<anything> the Boat

The <anything>, replaces the first part (Pass Thru) of Load the Boat.

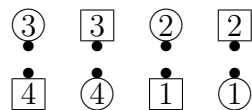

before Cross and Turn the Boat

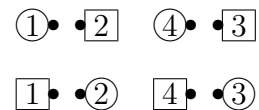

after

<anything> the Key

The <anything>, replaces the first part (Trade) of Turn the Key.

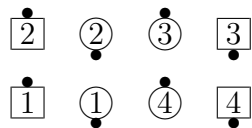

before Turn the Key the Key

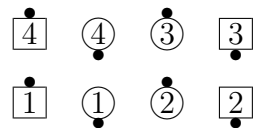

after

<anything> the Lock, <anything> the Top, <anything> the Hinge

See [Hinge the Top](#), page 83.

<anything> the Wave

See [Clover the Wave](#), page 42.

3x1 Flip/Cut Diamond

These calls are special, and not related to the more general meaning of 3x1.

A “3x1 Diamond” should be considered to be a diamond with a lot of centers. There is a wave or line of 6 centers, and two points. On a 3x1 Flip or Cut the Diamond, the centers all Counter Rotate, moving out far enough to leave room for the points to Flip or Cut.

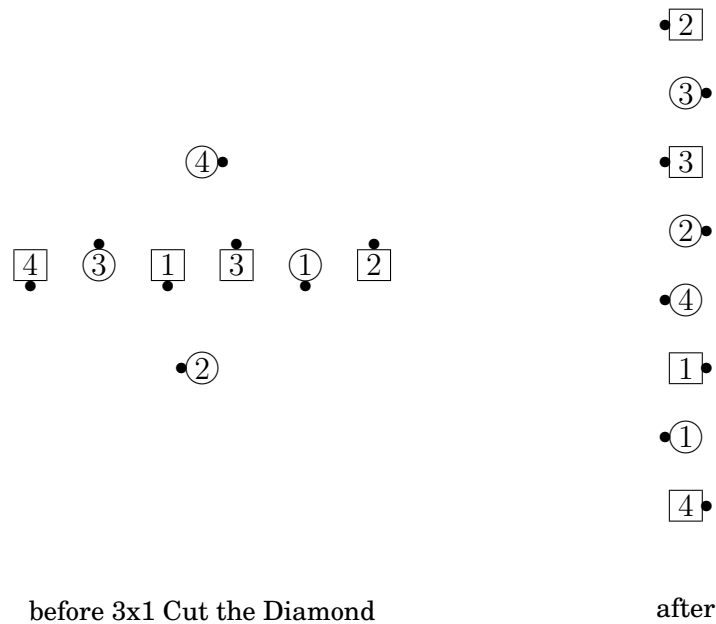

About

This is just Explode.

All 8 Cross Cycle

This is just a Cross Cycle variant of the C1 call All 8 Recycle. That is, Cross Concentric Cross Cycle.

All 8 Cycle and Wheel, All 8 Cycle and Turn and Deal

This is just the appropriate variant of the C1 call All 8 Recycle. That is, Centers Cross Concentrically Wheel and Deal or Turn and Deal, while the ends Cross Concentrically Recycle.

Alter the Diamond

Counter Rotate the Diamond 1/2 (or whatever amount is specified), Flip the Diamond, and Fan Back. This has three parts—the diamond Counter Rotates count as one part.

An Anchor, <anything> An Anchor, An Anchor but <anything>

From a tidal wave: very ends Counter Rotate and be ready to Pass In with someone who will appear shortly, while the other 6 trade. Then the very ends of the wave of 6 Counter Rotate and Pass In, while the remaining 4 trade. Finally, the center 2 trade.

On An Anchor but <anything>, the <anything> replaces both the Swing and the Slip for the center 4.

This is commonly used as a suffix. The initial call is often Swing. Note that, on Swing an Anchor, people trade in decreasing numbers from 8 to 2, with alternating hands. The sound effect is often “8, 6, 4, 2” for this. For a plain Anchor, the sound effect is “6, 4, 2”.

Another common initial call is “Cast” which, in this context, means Cast off 3/4.

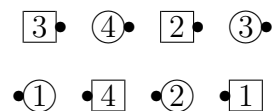

before Cast an Anchor

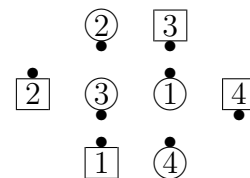

after

Anchor <N/4>

See [Right/Left Anchor](#), page 117. This is always given with a direction.

Area Code

This is somewhat like Outer Code. It is done only by the outsides, and they must be as if in columns. They Quarter Out, and then continue as if on a Zip Code for which they have now done zero. On an Area Code 1, they then do an Ends Bend. On an Area Code 2, they then Pass Thru. On Area Code 3, they then do an Ends Bend, etc.

Away

Centers U-Turn Back, toward each other.

Bail Out

Centers Short and Sweet and then Counter Rotate, while the ends 1/2 Circulate and then Hinge.

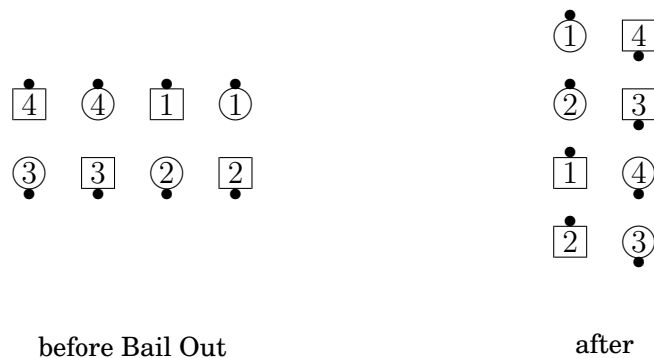

On Bail Out but <anything>, the <anything> replaces the centers' Counter Rotate.

This call has the nice (and commonly exploited) property of having separate actions for the centers and ends, with two parts for each action. Hence it is commonly used with Central, Invert Central, Invert, Snag, etc.

Barge the Action

This is a combination of "Barge Thru" and "The Action"—Square Thru 2; The Action.

See [Square the Barge the Action](#), page 148.

Barge Thru

Square Thru 2; Trade By.

See [Square the Barge](#), page 147.

Barrel of Fun

From any lines with the ends facing out: Ends bend and touch 1/2 while the centers quarter in and Swing Thru. Then all Fan the top.

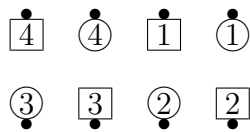

before Barrel of Fun

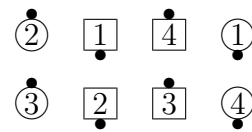

after

Beau Tie, Belle Tie

See [<anyone> Tie](#), page 159.

Beep Beep

This is Hinge and You All. The sound effect is “Hinge, You All”.

Bias Trade Circulate

This could be thought of as “Bias Circulate and Spread”. Leads Trade Circulate, while the trailers star across to their opposite.

Bits and Pieces

Centers: Peel and Trail, then Ah So.

Ends: 2 “O” Circulates, then Trade.

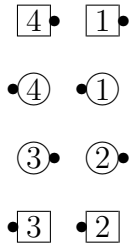

before Bits and Pieces

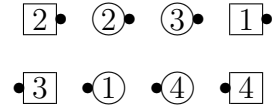

after

The centers and the ends each have 2 parts—the 2 “O” Circulates count as one part, though that part may be further subdivided.

The “usual” setup for this is some kind of lines. However, it is an extremely versatile call, and is commonly used with interesting modifications, such as centers (or ends, or everyone) work Reverse Order, or Snag someone, etc.

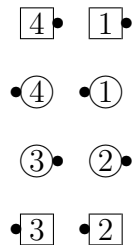

before Initially Central
Bits and Pieces

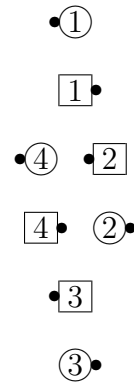

after

This can also be called when the centers are all facing in or all facing out. If they are facing in, the Peel and Trail is changed to a “Touch; Lockit; Lockit”. If they are facing out, it is changed to a “U-Turn Back; Touch”. You can think of this as doing your own part of Peel and Trail, and taking right hands upon colliding, but be aware that the actual call Peel and Trail has no such provision.

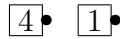

before Bits and Pieces



after

Brace Yourself

This is just the last half of a Brace Thru / Half Breed Thru: a normal couple does a Courtesy Turn, while a sashayed couple does a U-Turn Back.

<anyone> Break the Alamo

From an Alamo Ring: the designated people must be together in pairs. They identify a well-defined box, and Follow Thru and 1/2 Press Ahead. The others have the leader do a Loop 1 around the trailer. Then everyone connects to 2-faced lines.

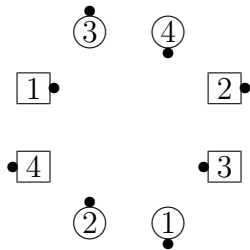

before Girls Break the Alamo

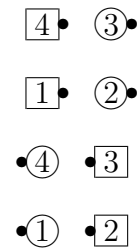

after

This is sometimes called from a T-boned 2x4, with the selected people in the center.

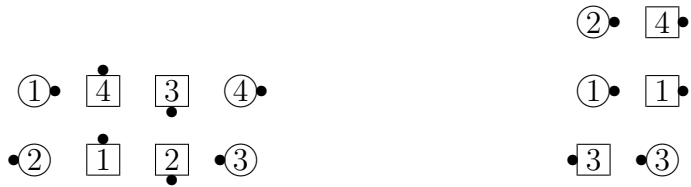

before Boys Break the Alamo

after

Bridge the Gap

This call suffers from having two definitions that are very different, but are compatible from the most common starting setup.

The official definition makes it a matrix (“space invader”) call. Beaus Press Left while the Belles Press Ahead and then Run/Trade/Flip Left. The belles will often find themselves trading with another person, but, if no one is there, they do a Phantom Run Left, or Left Loop 0.

The beau/belle identification occurs at the start of the call, based on whatever the matrix is.

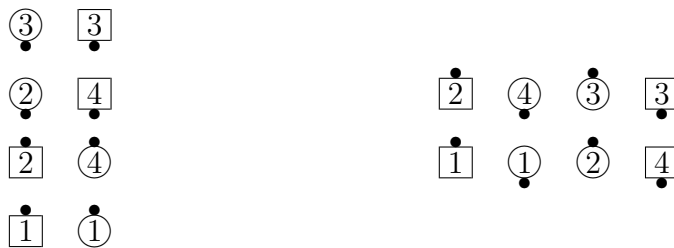

before Bridge the Gap

after

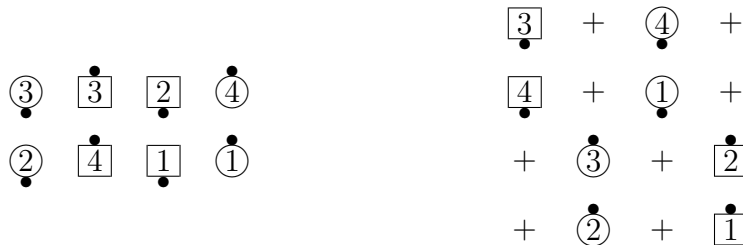

before Bridge the Gap

after

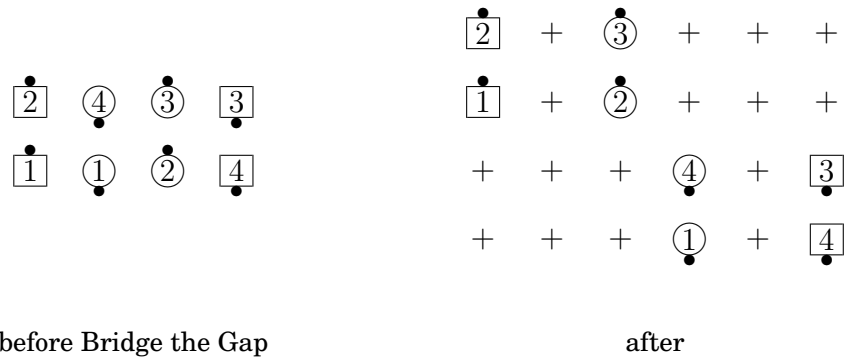

The first example above is a very common one, and is equivalent to Tandem Twosome Fan Thru to a Wave. This has led to an alternate usage, subject to modifiers such as Single and 3x3. Such modifiers would normally make no sense when applied to calls that are defined as completely general matrix calls. But they can be applied to Bridge the Gap if Tandem Twosome Fan Thru to a Wave is taken as its definition.

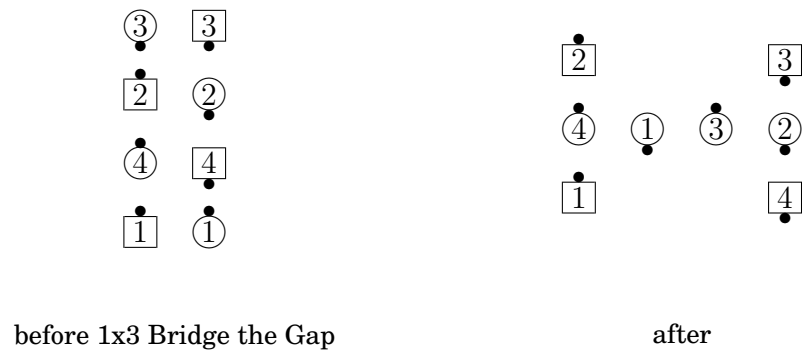
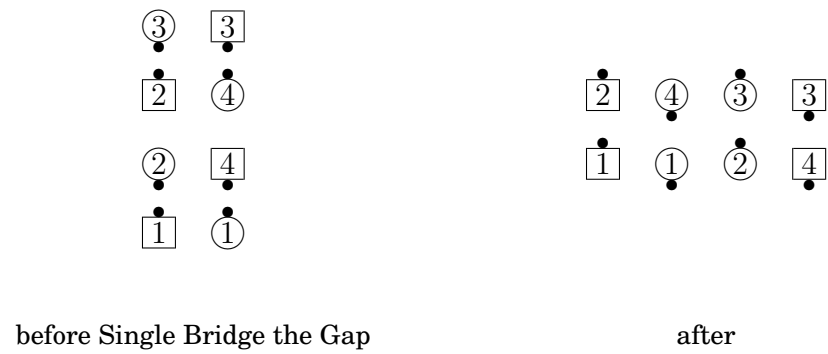

Bring Us Together

This call is usually used as a sequence starter. The designated couples move into the center, circle left (clockwise) 1/2, and slide out to the left ("Plus Two"). The other couples Single Rotate 1/4 and Phantom Follow Thru.

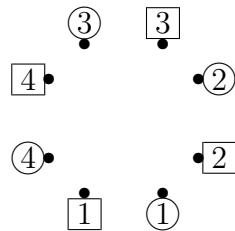

before Heads Bring
Us Together

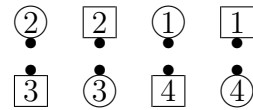

after

Of course this call is extended in a number of ways in challenge dancing. It can be done from a 2x4, equivalent to having had the the designated people already move into the center. In this case the designation of certain people is optional, but, if it is given, it must be the centers.

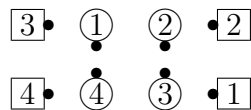

before Bring Us Together

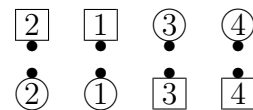

after

The circling distance can be modified.

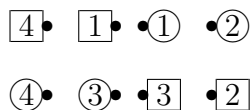

before 3/4 Circle
Bring Us Together

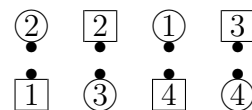

after

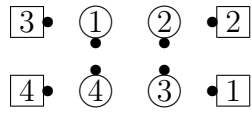

before Centers Work
Mirror 3/4 Circle
Bring Us Together

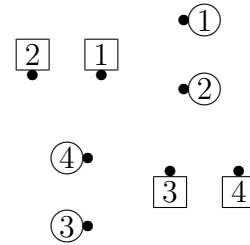

after

The call can be modified by such things as Single.

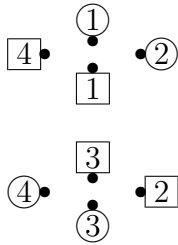

before Single
Bring Us Together

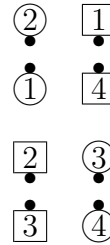

after

Buckle and <anything>

From any setup in which the ends are in line-like aspect, the end looking out Cross Folds, and the end looking in Circulates and Folds. The centers do the <anything> call.

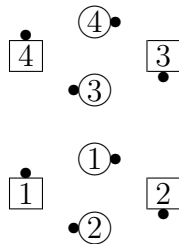

before Buckle and 2/3 Recycle

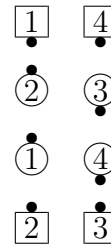

after

“Buckle” is sometimes used by itself, directed to the ends.

A possibly useful cheat is Counter Rotate and Roll.

By [By] [By]

See [Right and Left By](#), page 117.

Cast a Net

From waves or 2-faced lines (usually): 1/2 Circulate. There should then be a center line and outer pairs perpendicular to that line. The very centers cast 3/4 and Spread (outward) past one person. The outer pairs Trade, and the inner one of them Spreads inward, past the people in the previous sentence, to become very centers. The remaining person Counter Rotates to become the very end. The result should be some kind of tidal line.

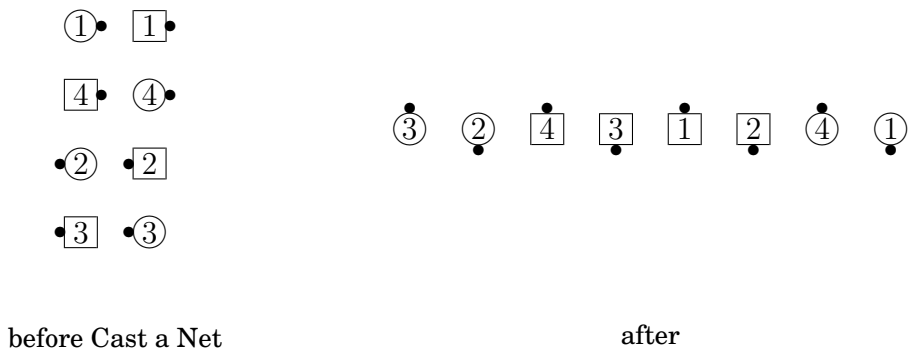

This call can be started in any setup from which a 1/2 Circulate leads to the required intermediate setup.

The initial 1/2 Circulate is a recognizable first part, and hence it is possible to do a Finish Cast a Net, which can lead to things like:

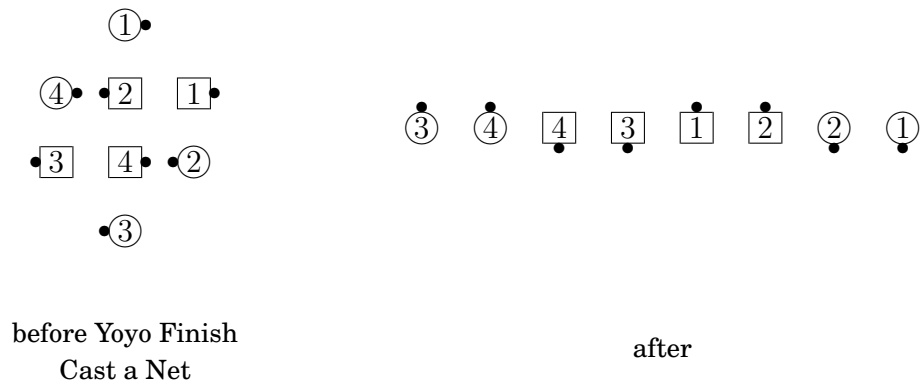

Cast an Anchor

See [An Anchor](#), page 23.

Cast Away

This is preceded by some kind of “Put Centers In” type of call that results in a couple. That couple does a Cast Off 1/2, with the person who moved forward doing the pushing.

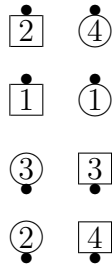

before Centers Left and Cast Away

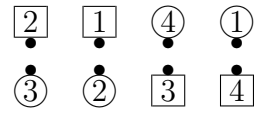

after

This can also be called with an explicit fraction.

Centers Cut Out

From lines, the centers Cross Over Circulate (that’s the “Cut Out”) while the ends flip in. A common sound effect for this call is “ends flip in”, which is useful, because the call often confuses people more than it ought to.

See [Ends Cut In](#), page 68.

Centers Out, or Put Centers Out

This is analogous to the Mainstream call Put Centers In.

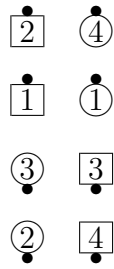

before Put Centers Out

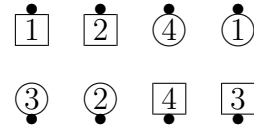

after

Centers Thru and Close the Gate, or Put Centers Thru and Close the Gate

Put Centers In, then Twist the Line.

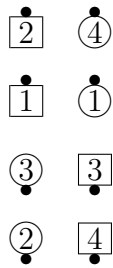

before Centers Thru and Close the Gate

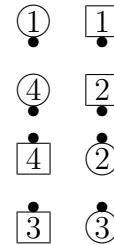

after

Change Jays

This is used after any call in a Jay, with a second Jay call. Everyone works in the geometrically opposite Jay. People in the center work with the outside spots other than the ones involved in the previous Jay call, and those new outside spots work with them.

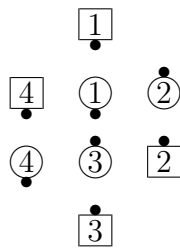

start

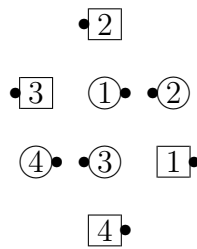

Left Jay Bingo

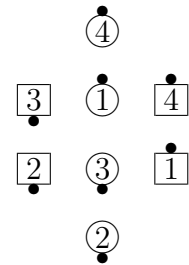

Change Jays and
Bingo again

Change Lanes

This is an old Advanced Quarterly Selection. In modern terminology, it is just 1/4 Chain and Circulate In. (It was defined, for Advanced dancers, as centers (any hand) Remake and Spread while the ends Circulate and Cross Over Circulate.)

There was also a call Retain Your Lane. Centers (any hand) Remake while the ends Circulate twice.

This can be done when the centers are T-boned to the ends. The Spread after the Remake is always lateral.

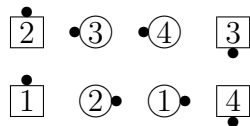

before Change Lanes

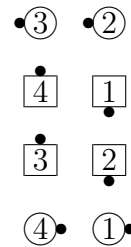

after

It can also be done when the ends are the ends of columns, and they do their final Cross Over Circulate in columns.

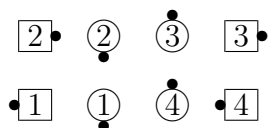

before Change Lanes

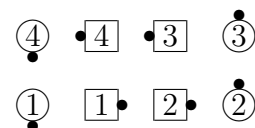

after

[Reverse] Change-O

Change-O, from columns (typically normal ones): #1 and #2 Circulate, #3 and #4 Cross Over Circulate.

Reverse Change-O, from columns (typically magic ones): #1 and #4 Circulate, #2 and #3 Cross Over Circulate.

Perhaps a useful way to remember this and make sense of it is as follows: Think of a magic column as one in which the ends are “correct” and the centers are “wrong”. (Some people actually think this is true. Good challenge dancers know better. It is just an artifice for these calls.) Then Change-O means “Circulate while going into magic”. That is, cross over if you will finish in the middle. Reverse Change-O means “Circulate while coming out of magic”. Cross over if you started in the middle. Of course, if you can figure out what to do in time to do it in one smooth motion rather than two separate actions, so much the better.

Change the Apex

This is just Hinge By, restricted to triangles.



before Outside Triangles
Change the Apex
 $1/4 \times 3/4$

after



before Inside Triangles
Change the Apex
 $1/4 \times 1/2$

after

Change the Web

From a $1/4$ tag: the center wave does a Swing and the very centers Cast $3/4$ while the ends of the wave move forward. The outsides adjust to make two stars, in the same way stars are formed on

Explode the Top. The stars turn 5/4 (yes, 5/4.) Then the people who find themselves in the very center Cast 3/4 with each other, while the people behind them in the stars move forward to become ends of the center wave. The others adjust to become outsides of a 1/4 tag.

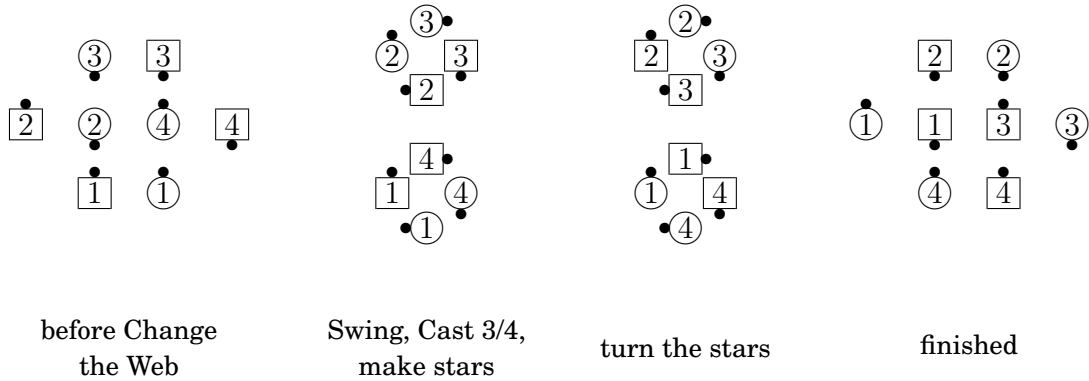

Chase the Tag <N/4>

This is a tagger, and is the basis for the C1 call Chase Your Neighbor.

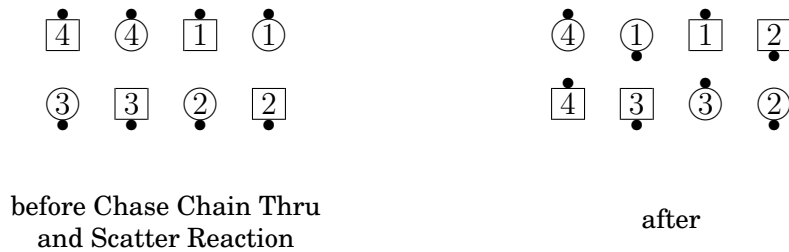

From back-to-back couples, the belles U-Turn Back to the right, and all Box Circulate. You are now at the 1/2 tag position. Proceed (or back up) as required.

Cheerio

From general columns: centers Tag with each other, Press Ahead, and Face In. ("Squeeze like a Couple Up.") Among the ends, the lead Runs, and then they Press Ahead. If both ends are leads, they Trade before pressing ahead. If neither is a lead, they do *not* sashay. They simply Press Ahead as they are.

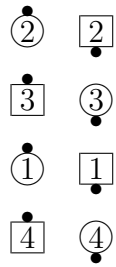

before Cheerio

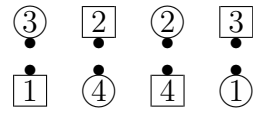

after

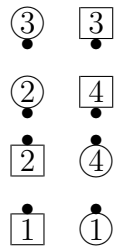

before Cheerio

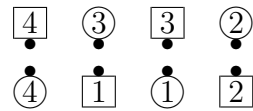

after

Chip Off

From lines with at least one pair of people forming a couple facing out: The couple facing out, or the couple on the right if both are facing out, Link Up. The other center does a Shove Off inward, taking the adjacent end.

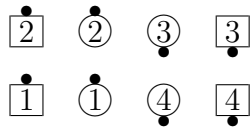

before Chip Off

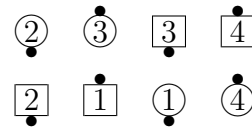

after

Circle to a 2-Faced Line

As couples Single Circle to a Wave. That is, Circle 1/2, then Veer Left.

Circle <N/4> to a Wave

From facing couples: circle clockwise the indicated amount, With the Flow. This is just a generalization of the C2 call Circle to a Wave, which is seen to be Circle 1/4 to a Wave.

Circle the Tag <N/4>

This is a tagger. Circle to a Wave. You are now at the 1/2 tag position. Proceed (or back up) as required.

Clean Sweep <N/4>

This has 4 parts. From facing couples, Sweep <N/4> clockwise, Veer Left, Tag the Line, Leads Roll Right to a Wave. The sweep is always clockwise (unless the caller said "Reverse" or "Mirror".) If that isn't the same direction that a plain Sweep 1/4 would have obtained, the awkwardness is the caller's fault.

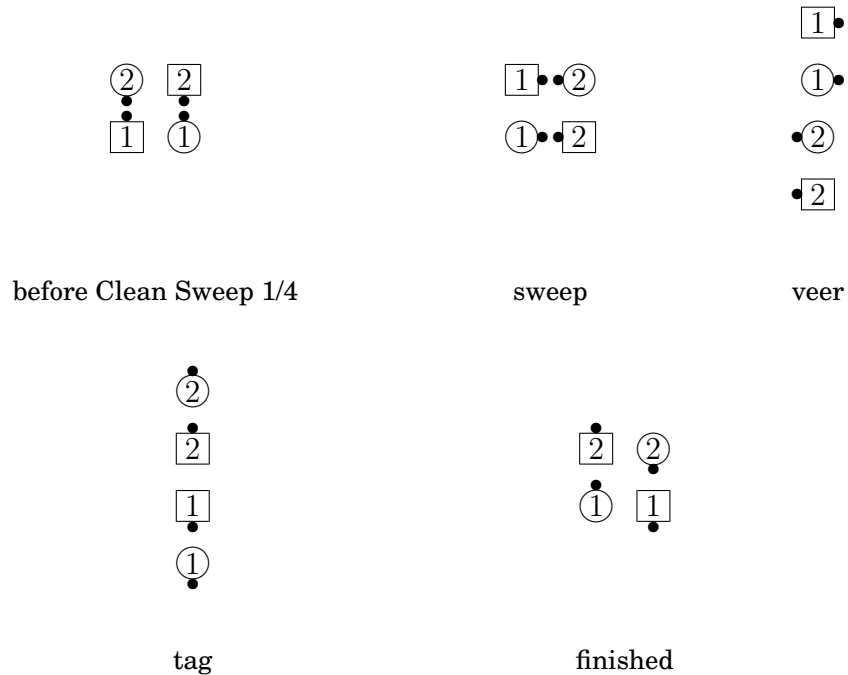

If the caller says "Reverse" or "Mirror", all parts are reversed: Sweep counterclockwise, Veer Right, Left Tag the Line, leads Roll Left.

Clear Out, <anything> Clear Out

Clear Out is Circulate followed by centers Couple up while the ends “Like a Couple Up”. That is, the ends U-Turn Back if needed to face into their box of 4.

Since this starts with a Circulate, it is subject to the C2 “anything anything” rules. A circulate modifier may be given, as in “Bias Clear Out”, or a call may be given, as in “Percolater’s Clear Out”.

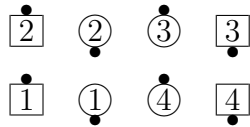

before Bias Clear Out

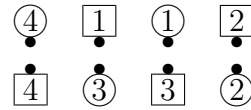

after

One also commonly hears Finish Clear Out. The ends must resist the temptation to go anywhere. They just U-Turn Back if necessary.

Clear the Centers for <anything>, Clear the Centers but Cross It for <anything>

From a 1/4-tag-like formation: centers start a Linear Cycle and then Tandem Run outward. (This is typically around the nearest ends.) The ends move in and do the <anything>. If the “Cross” modifier has been given, Tandem Cross Run outward, around the far ends.

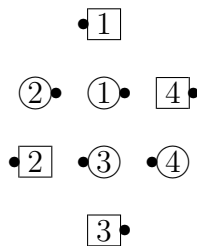

before Clear the Centers for a Bingo

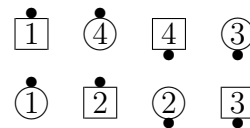

after

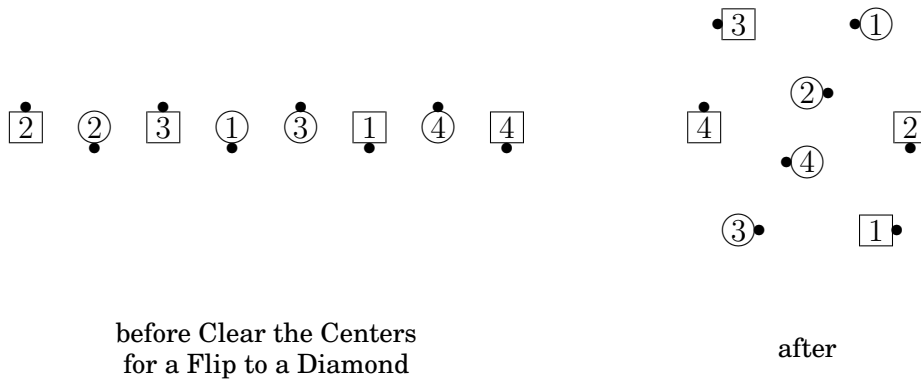

Clear the Way, Clear the Way but Cross It

From a 1/4-tag-like formation: centers do the same as on Clear the Centers. The ends Hinge twice, Vertical 1/2 Tag into the center, and Counter Rotate.

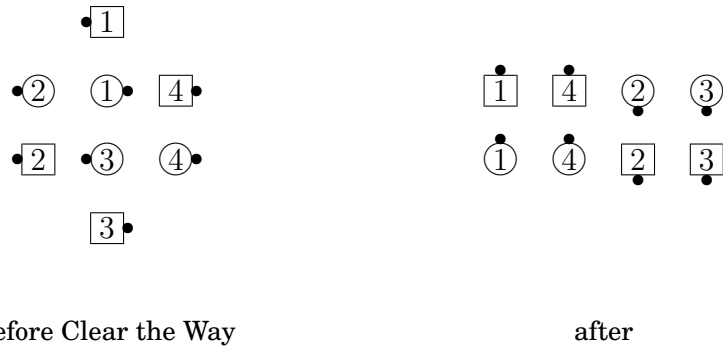

Clover Flow

From a Trade by: ends Cloverleaf and then Pass Thru when they get into the middle. Centers Pass Thru and then Cloverleaf.

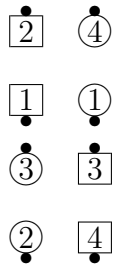

before Clover Flow

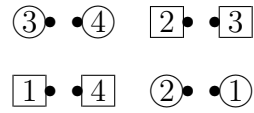

after

Cross Cloverleaf

Considering that Cross Clover and <anything> is on the A1 program, this has to be the world's most seriously orphaned call.

Everyone crosses.

[Cross] Clover the Horn

This starts like Cloverleaf (or Cross Cloverleaf) and ends like Round the Horn. The leads finish the Cloverleaf and Pass Thru with each other in the center. The trailers don't do the final 1/4 turn of the Cloverleaf—when they find themselves facing each other on the outside, they Pass Thru.

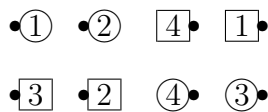

before Clover the Horn

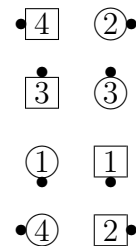

after

Clover the Wave, <anything> the Wave

From waves: <anything> the Wave means Extend twice to a completed DPT, and then do the <anything>.

This family started as Peel the Wave and Trail the Wave, and expanded from there. Because the phrase “the Wave” is spoken at the end of the call, but affects the beginning, it has a rich history of humorous abuse. We do not endorse Revert the Cross Loop and Tag Chain Thru and Scatter Cross Reactivate to a Diamond Your Leader the Wave.

Cloverleaf Turn, Cloverleaf Turn Reaction, Cloverleaf Turn Reactivate, Cloverleaf Turn Nuclear Reaction

Cloverleaf Turn is like a Clover Flow, but each Pass Thru is replaced with a Turn Thru. In the case of things like Cloverleaf Turn Reaction, the final Turn Thru is done as a Turn Thru to a Wave, to set up the final part.

The calls Cloverleaf Turn Reaction, Cloverleaf Turn Reactivate, and Cloverleaf Turn Nuclear Reaction are analogous to Scoot Reaction. The final Turn Thru of the Cloverleaf Turn is replaced with a trade, and then the final call is done.



before Cloverleaf Turn Nuclear Reaction

after

Collapse

This is usually Collapse the Diamonds. Ends Detour while the centers Step and Fold.

One can also Collapse the Hourglass, or other setups.

On an Interlocked Collapse, the centers Step and Cross Fold.

Complete the Tag

Extend, from any tagging position, all the way to a completed DPT.

Connect the Diamond

From normal diamonds, this is equivalent to Drop In and then Counter Rotate. It also feels somewhat like Crossfire.

From diamonds: centers Hinge and Extend, while the points Fold or Cross Fold (usually Cross Fold) as necessary to go into the unoccupied spot.

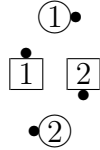

before Connect the Diamond

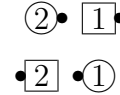

after

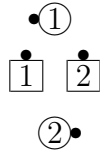

before Connect the Diamond

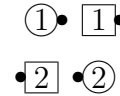

after

Continue to [Magic] [Cross] Invert

This continues an Invert the Column, from wherever the partial invert has finished, for one more quarter, or however many additional quarters the caller says. Recognizing a partially completed Invert the Column can be tricky. If you are in waves, the invert has gone 1/2, and the center of the wave looking out is the person who has the important part.

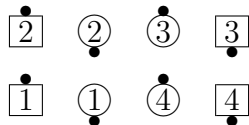

before Continue to Invert
another 1/4

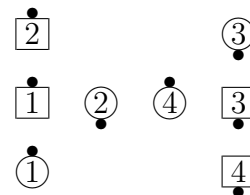

after

Contour the Line

Hinge, Split Circulate, Split Circulate, Hinge.

This has 4 parts, and its division into parts is frequently exploited.

Convert the Triangle

This is two rather dissimilar calls, depending on the type of triangle.

From a tandem-based triangle, the lead base does a sort of 1/2 Run, to become the apex of a new triangle. The apex and trailing point extend to each other to become a new wave base. Think of the call as sort of a “1/2 Circulate”.

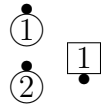

before Convert the Triangle

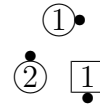

after

From a wave or couple-based triangle, this can be quite tricky. The apex steps ahead, usually (but not always) to become the lead base of a tandem-based triangle. Any wave or couple-based person who is “infacing” (facing toward the apex) steps forward *behind* the original apex and turns to be tandem behind her. Any “outfacing” base person does 1/2 of a Run, usually to become the new apex.

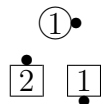

before Convert the Triangle

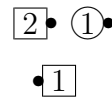

after

Infacing base people always step behind the original apex, even if the triangle is facing:

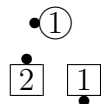

before Convert the Triangle

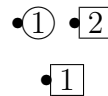

after

If both base people are infacing, they both step behind the apex, maintaining their order. In this case the result is a column of 3.



before Convert the Triangle

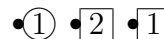

after

Cooperate

From columns: Circulate. Half Circulate. The columns of 6 then Invert the Column 2/3. The resultant center diamond Drop In.

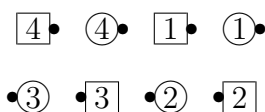

before Cooperate

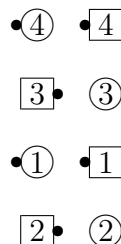

after

The celebrated cheat for this is Tandem Reach Out.

Since this starts with a Circulate, it is subject to the “<anything> Cooperate” construction, as in “Split Counter Cooperate” or “Triple Scooter’s Cooperate”.

On Cooperate but <anything>, the <anything> replaces the centers’ Drop In.

Coordinate to a Diamond

See [Reactivate to a Diamond](#), page 110.

Counteract

Normally from columns: ends Trade and Split Counter Rotate, while the centers Counter rotate and “anchor the (new) trailing center for a Trade”. That is, the new lead center does a Cross Run while hanging on to the trailing center. The effect of this is that the trailing center will do a U-Turn Back.

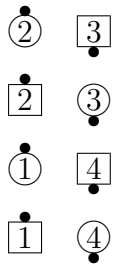

before Counteract

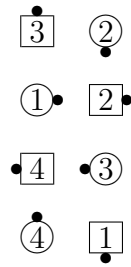

halfway

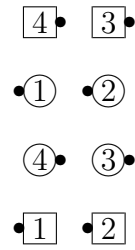

finished

While this call has a simple feel to it in the normal situation, it is commonly used at C4 in ways that require knowledge of its precise definition.

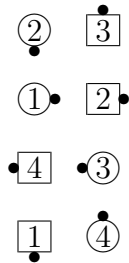

before Counteract

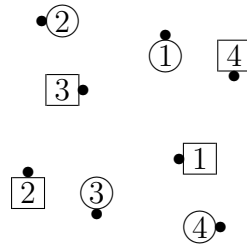

after

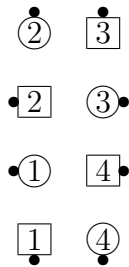

before Counteract

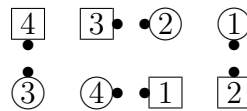

after

[Cross] Counterpoint

Centers Recycle (whatever kind of Recycle is appropriate) while the ends counter rotate. If the “Cross” modifier is given, the centers Cross Cycle.

Countershake

This call is difficult because the precise definition, with parts, is sometimes violated by some concepts, and replaced by something related to its “feel”.

It is usually done from a completed DPT. Ends 1/4 right, Counter Rotate, and Twosome Drop In. Centers Shakedown, Veer Left, and As Couples Extend.

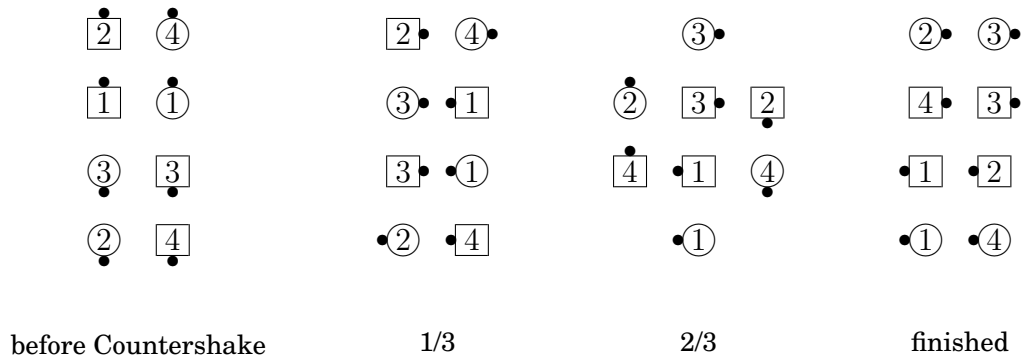

It has the feel of a Concentric Shakedown and solid box of 4 Touch. This is sometimes used in, for example, 3x3 Countershake from a 2x6 matrix completed DPT.

Cover Up

Circulate. Half Circulate. Centers Recycle while the ends natural Pass In.

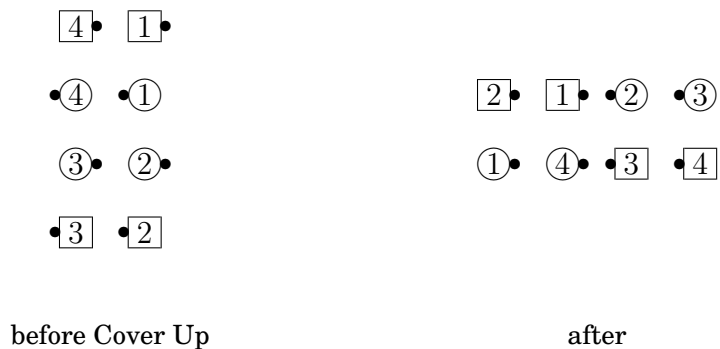

Since this starts with a Circulate, it is subject to the “<anything> Cover Up” construction, as in “Bias Cover Up” or “Remaker’s Cover Up”.

On Cover Up but <anything>, the <anything> replaces the centers’ Recycle.

When done from inverted lines, after the Circulate 1-1/2 the determination of who are the centers and who are the ends must be made carefully. The rule is that “the centers stay centers”—it is the same rule as for Tally Ho.

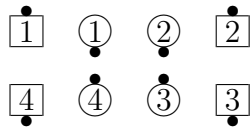

before Cover Up

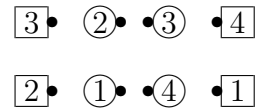

after

Crackle

Typically from a Trade by: centers Touch (if necessary) and Lockit, while the ends Hinge.

See [Snap, Crackle, and Pop](#), page 141.

Create a Column

From any distorted column in a 4x4 matrix: If you are in the center phantom columns, do two normal Column Circulates. Otherwise, do two Butterfly or “O” Circulates, as appropriate.

The common “cheat” way of thinking about this is: everyone does two Column Circulates while adjusting inward to make normal columns.

Create a Diamond

This is just Slant Touch and 1/2 Tag. It’s always a right Touch.

Criss Cross the Diamond

Criss Cross the Deucey; Centers Hinge; Diamond Circulate; and Centers Hinge.

Compare this with Trade the Diamond.

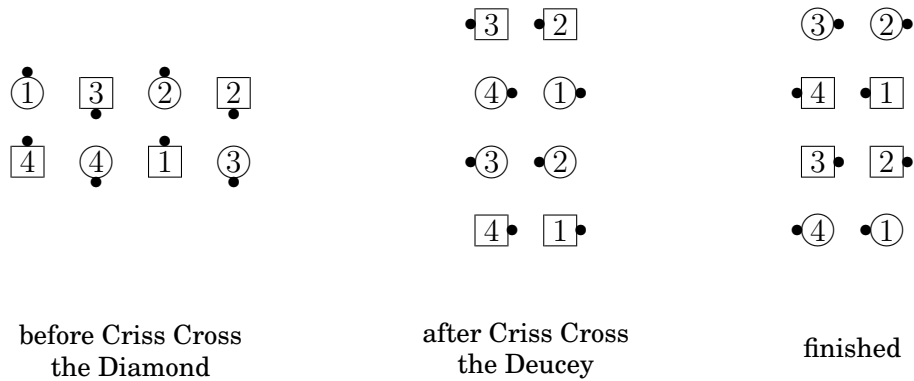

Cross and Divide

From any line of 4: The centers do 1/2 of a Cross Run to finish on one side of a couple facing out. The ends Quarter Out and get on the appropriate other side of the resulting couple.

The centers control this through their 1/2 Cross Run action. The ends must watch to see which side they are approached from. The call may be smooth:

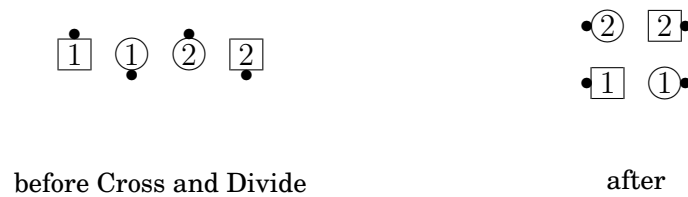

or not so smooth:

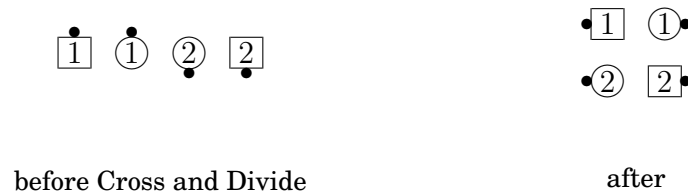

Cross Breed Thru

This call has its historical roots in the details of what “Cross Trail” used to mean. The modern definition is: Slide Thru, and any trailers Pass Thru, passing left shoulders.



before Cross Breed Thru

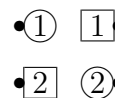

after

Cross Cycle

In addition to the “Cross” version of the ordinary wave Recycle, there are cross versions of facing Recycle and Split Recycle. These are equivalent to doing the Recycle followed by a Slither. But the facing couples version is best done by having the beaus step into the center and Trade by the right. It is the same as Hammerlane.

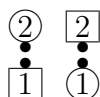

before Cross Cycle

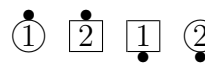

after

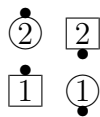

before Cross Cycle

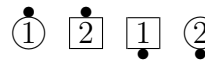

after

Cross Drop <direction>

On a Cross Drop, the centers come out to opposite hands, as if doing a Cross Extend. The points, as usual, have to get out of the way appropriately.

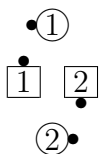

before Cross Drop Out

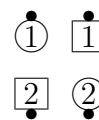

after

Cross Follow Thru

This is a Follow Thru with people extending to the opposite hand from the normal one. From a box, it is a Weave. From a 1/4 tag, it is a Cross Extend and Hinge.

Cross Horseshoe Turn

Outsides Cross Cloverleaf; centers Quarter In and Cross Trail Thru.

Cross Linear Cycle

This is like a Linear Cycle, but the initial Hinge is a Once Removed Hinge.

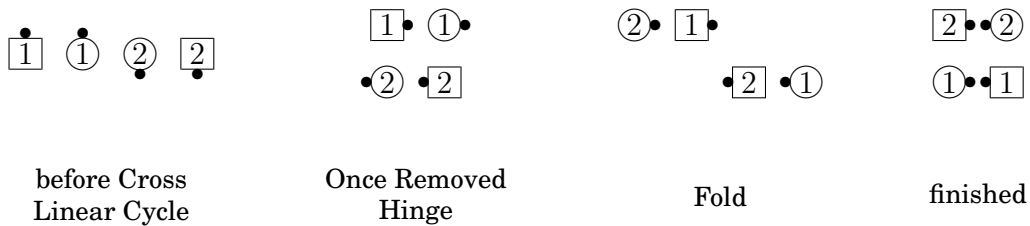

Under benign circumstances, this begins just like Cross Flip the Line, and is equivalent to Cross Flip the Line 1/2 and Couple Up, just as ordinary Linear Cycle is usually equivalent to Flip the Line 1/2 and Couple Up. However, Linear Cycle is not restricted to waves, and Cross Linear Cycle is not restricted to 2-faced lines. The initial Once Removed Hinge may be a Partner Hinge.

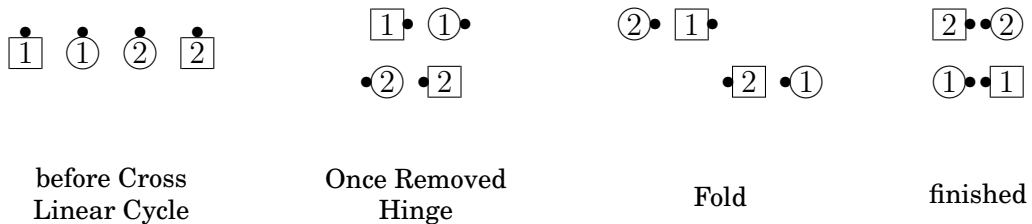

Cross Sashay

Think “Slithery Crossfire”—the centers Slither instead of trading. From a wave, centers Slither and step ahead, while the ends Cross Fold.

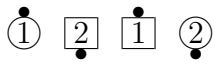

before Cross Sashay

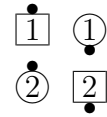

after

Cross Scoot and Weave

This is like Scoot and Weave, but people cross to the opposite hand when they first meet to trade. People coming in to the center the second time for the Hinge cross hands as usual.

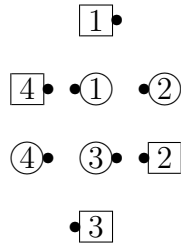

before Cross Scoot and Weave

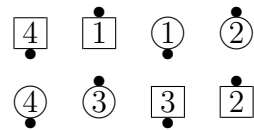

after

Cross the Ocean

Vertical 1/2 Tag and Weave. The original intent of this call was something like Half Sashay blending into Pass the Ocean.

Cross the Top

Spin the Top and Spread.

Cross to a Diamond, Hourglass etc.

Usually from lines: Centers Cross Over Circulate while the ends slide together and Hinge.

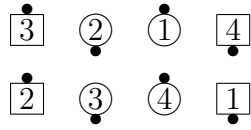

before Cross to a Diamond

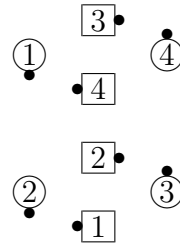

after

One can also Cross to an Interlocked Diamond, Hourglass, etc. See the discussion of <ATC> to a Diamond.

This call is often danced clumsily, probably because people are trying very hard to avoid confusing it with Cross to a Wave.

Sometimes this is tricky and requires a creative formulation of Cross Over Circulate:



before Cross to a Diamond

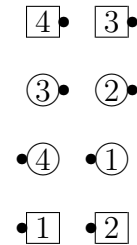

after

Cross to a Wave

Usually from diamonds: Points Cross Over Circulate while the centers Hinge and slide apart.

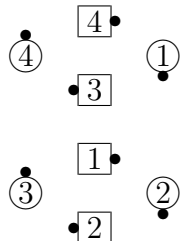

before Cross to a Wave

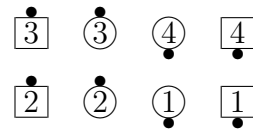

after

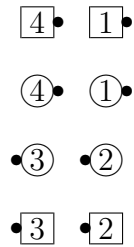

before Cross to a Wave

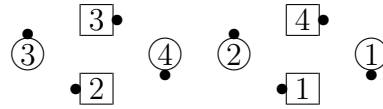

after

This call is often danced clumsily, probably because people are trying very hard to avoid confusing it with Cross to a Diamond.

Cross Town Roll

This is an old traditional call that has some of the feel of part of the folk dance “Salty Dog Rag”. The precise-for-challenge definition could be described as: Those who have handholds do the equivalent of a Trade by that hand and extend, except that they don’t go around each other on the Trade. They push back from each other and do the “Trade” in front of each other rather than around each other.

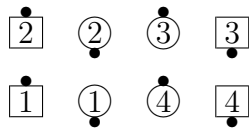

before Cross Town Roll

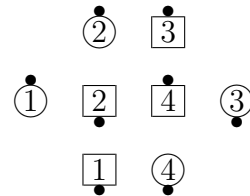

after

The “extend” can be T-boned. The handedness rule, dictated by the centers, still applies:

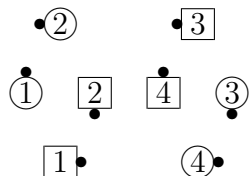

before Cross Town Roll

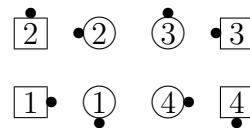

after

Cross Walk and Dodge

Like a Walk and Dodge, but the trailers cross over. Or, Stable Split Trade Circulate.

Curl Apart

From a 1x4: centers Trade while the ends Cross Fold. Then the centers flip away while the original ends Press Ahead into that space.

The universally used “cheat” is Slip and Switch.

This is often confused with Curl Thru. Neither call is very common.

Curl Thru

This is a Crossfire without the final step ahead (extend). It therefore ends in a Z.

This call is very uncommon. It is often confused with Curl Apart.

Curlique

This is a gender-dependent call. It is sort of a Box the Gnat ending in a miniwave. For the boys it is essentially a Touch 1/4 with funny hand action. The girl goes under the raised arch, turning 3/4 to the left. The call is equivalent to Touch 1/4.

Curli Cross

Curlique and Cross.

Curli Cross the Top

Curlique and Hinge the Top.

Curli Wheel

Curlique, then the new trailers walk forward to crossed (left) hands with each other, Trade, and step back. While the trailers are doing that, the leads Run right.

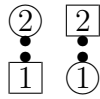

before Curli Wheel

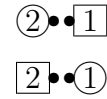

finished

Curli Pass

Curlique, then those facing, wherever they are, Pass Thru.

This is often used at the start of a sequence.

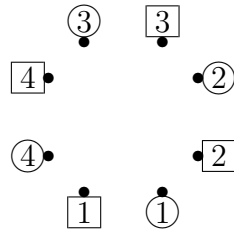

before Heads Curli Pass

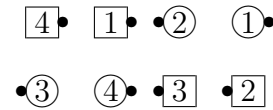

finished

< anyone > Curve < direction >

This is a space-invader. It is like Press, but there is a 1/4 turn in the indicated direction. "Ahead" is of course not legal.

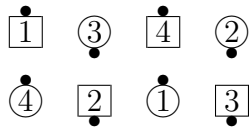

before Boys curve Right

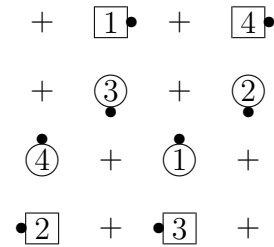

after

If the direction is “in” or “out”, it is relative to the whole formation.

Cut Across

From any kind of 2x4: Identify whether you are a leader or a trailer (in your box of 4). Then, working to concentric box spots, if you were a leader do a Partner Tag and then trade, and if you were a trailer do a trade and then Partner Tag. These actions are always done concentrically, no matter how awkward that might be. The “lines to lines” rule does not apply, however. Work to spots.

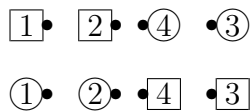

before Cut Across

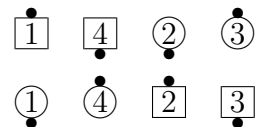

after

[Reverse] Cut the <formation>

In analogy with Cut the Diamond or Hourglass, in Cut the <formation> those who are far apart slide together and Trade, while the others <formation> Circulate.

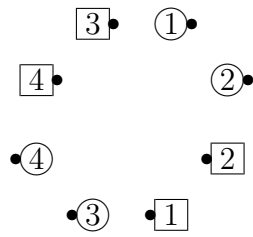

before Cut the O

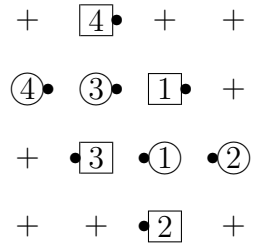

after

On Reverse Cut the <formation>, those who are close together Trade and slide apart, while the others <formation> Circulate.

Cycle and <anything>

This is like Cycle and Wheel, with the <anything> replacing the Wheel and Deal. It is typically a Cycle and Turn and Deal.

[Cross] Cy-Kick

This is pronounced “psychic”. Centers 2/3 Recycle, while the ends do a Beaus Kickoff.

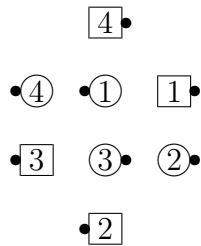

before Cy-Kick

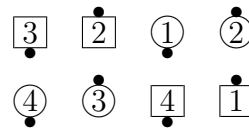

after

On a Cross Cy-Kick, the centers do a 2/3 Cross Cycle.

Derby

See [Dixie Derby](#), page 64.

Detach

Centers Counter Rotate and Roll, while the ends Zing and “move up”. The ends’ part is the same as for Easy Does It.

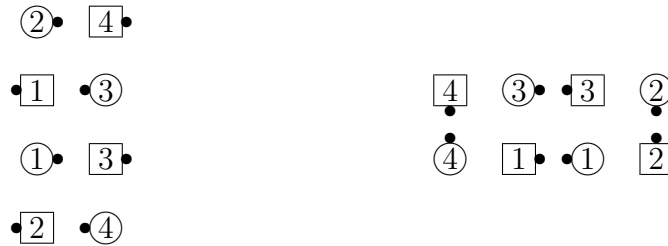

before Detach

after

Detract <N>, Detract <anything>

This call is rather similar to Breaker. The ends Detour and then Hinge. The centers Box Counter Rotate and then 1/2 Box Circulate. Then those who meet Cast Off the indicated amount, or do the <anything> call, while the others “move up”.

The ends may begin either as ends of lines or ends of columns when they do the 1/2 Zoom of the Detour—the call is similar to Disband in this regard. Since they do a Detour followed by another Hinge, one can usually think of this as a 1/2 Zoom and Trade, that is, Strip. However, if the call is fractionalized, it is necessary to know the actual definition in terms of Detour and Hinge.

The centers’ part, like that of Breaker, can usually be thought of as “turn the star 1/4 and a little more, until some people line up with the ends”. However, if the call is fractionalized, it is necessary to know the actual definition in terms of Box Counter Rotate and 1/2 Box Circulate.



before Detract Flip Back

after

Deuces Wild

From lines: centers trade while the ends Zoom.

Diamond Inlet, Diamond Outlet

These are like Inlet and Outlet, but involve diamonds rather than 1/4 tags, through appropriate fudging of the turning motion.

On a Diamond Inlet, the outer active people (end looking out and adjacent center) do a 2/3 Recycle instead of a full Recycle. This may also be called Inlet to a Diamond.

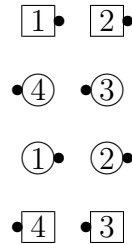

before Diamond Inlet

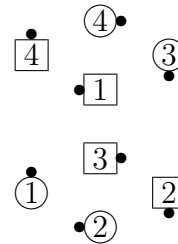

after

On a Diamond Outlet, the outsides do a Split Circulate and Hinge.

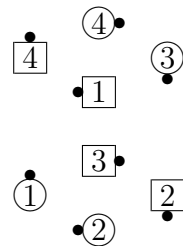

before Diamond Outlet

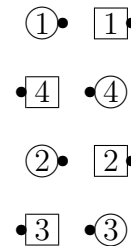

after

Diamond Recycle

From a diamond: centers Hinge, all Wheel and Deal.

One can also do a “facing Recycle” version or a “Split Recycle” version—those coming in to the center Hinge with each other instead of a U-Turn Back.



before Diamond Recycle

after

Divide

This call is directed to the ends, who must be in generalized columns. They 1/4 Out and do an Ends Bend. They are then typically directed to do some call. It is perhaps more simply viewed as an “O” circulate if facing in, or a Cast Back if facing out.

It’s really just an old name for what is now called “separate” at Mainstream.

Divide and Pair

Typically from a Trade by: ends Divide and Pass In, while the centers 1/4 Out.

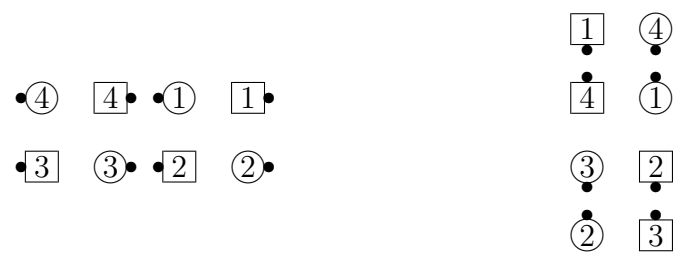

before Divide and Pair

after

Divvy Up

Centers Single Wheel, while the ends Divide so that they are facing each other.

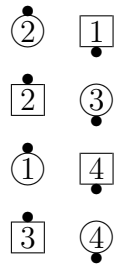

before Divvy Up

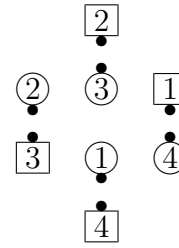

after

Dixie Chain

Belles step ahead, Right Pull By with each other, and Left Pull By with the others, who then Right Pull By with each other.

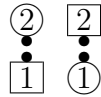

before Dixie Chain

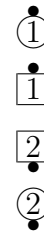

after

When done Single File, this is equivalent to a Double Pass Thru. The modifier “Single File” is often omitted in this case. It can also be done Split:

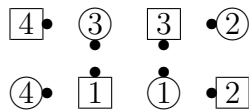

before Split Dixie Chain

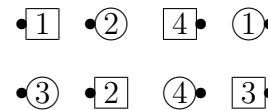

after

Dixie Daisy

This is like Dixie Chain, but the Left Pull By is replaced with a Left Turn Thru. Belles step ahead, Right Pull By with each other, Left Turn Thru with the others, and then Right Pull By with each

other.

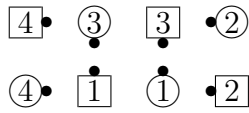

before Split Dixie Daisy

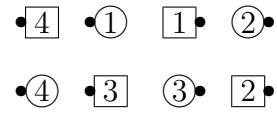

after

Dixie Derby, Derby

On a Derby, the centers Trade and Spread, while the ends Fold. Then those who Folded step forward into the space in the center.

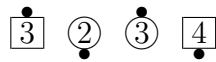

before Derby

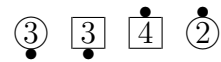

after

A useful cheat for this is Cross Roll. However, it is occasionally necessary to know the true definition:

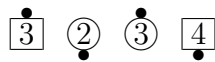

before Yoyo Derby

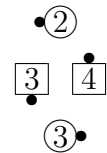

after

Dixie Derby is Dixie Style to a Wave followed by Derby.

Dixie Hourglass, Dixie Interlocked Diamond

These are the appropriate variations of Dixie Diamond. See the discussion of <ATC> to a Diamond.

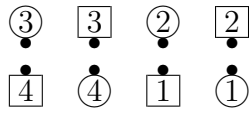

before Dixie Hourglass

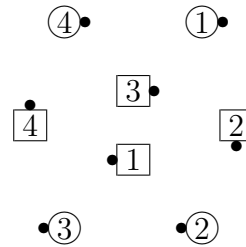

after

Dixie Spin

Dixie Style to a Wave, then Fan the Top. This has two parts. The full Dixie Style is the first part.

[Cross] Double Down

Normally from waves: The trailing end and adjacent person do two Split Circulates. The others do one All 8 Circulate.

On a Cross Double Down, the All 8 Circulate is replaced with a Cross Over Circulate. The two Split Circulates are not changed.

In waves, it is common for the trailing end to hang on to the adjacent person, and drag them around for what looks more like a Counter Rotate 1/2. But you should remember that it is actually two Split Circulates.

If done from columns, the “trailing end” is the #4 person. He and the person lateral to him do the two Split Circulates.

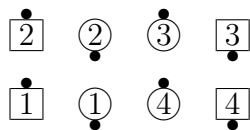

before Double Down

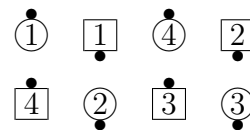

after

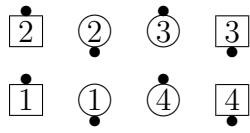

before Cross Double Down

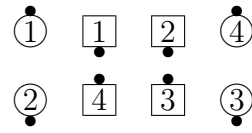

after

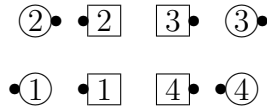

before Double Down

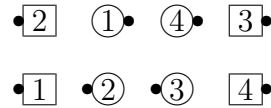

after

The people who do the two Split Circulates are the trailing end and the person laterally adjacent to him.

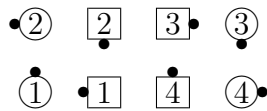

before Double Down

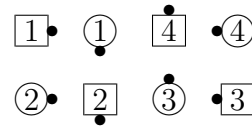

after

Double the Wave

Fan the Top, then the center 2 Trade. This is 2/3 of a Hot Foot Spin.

[Cross] [Criss Cross] Double Your Pleasure

This is sort of a gigantic Peel and Trail.

From columns: #1 Peels and Circulates to become the lead end of waves. The other 6 Extend and Trade. Then #1 of that group Peels to become the trailing end of waves, while the others Extend and Trade.

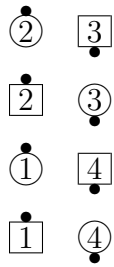

before Double Your Pleasure

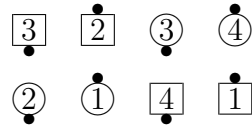

after

Cross Double Your Pleasure is sort of a gigantic Trail Off. The Peels are replaced by Trails.

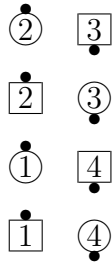

before Cross Double Your Pleasure

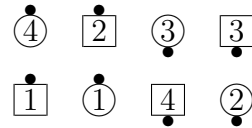

after

Criss Cross Double Your Pleasure is like Cross Double Your Pleasure, but each time people extend, they take the opposite hand. This usually results in collisions at the end.

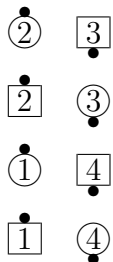

before Criss Cross Double Your Pleasure

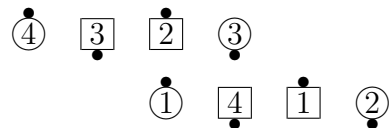

after

Dream

See <ATC> er's [Dream/Nightmare](#), page 16.

Drift Around

From back-to-back couples: This is simply a Ripoff restricted to this setup. Beaus Run while the Belles Zoom.

Easy Does It

Usually from lines: Concentric Zing.

This call is easily confused with Ease Off. In fact, the end's part is so similar (Zing) that they often fail to “move up” as required by the Concentric rule. Also, the centers frequently fail to Zing, perhaps because it is awkward to do so in the center. Hence, the sound effect for this is “everybody does it”, meaning that everyone, including the centers, does a Zing.

Eight Roll Away with a Half Sashay

Trade, then U-Turn Back toward each other, that is, Roll twice.

Ends Cut In

From lines, the ends Cross Over Circulate (that's the “Cut In”) while the centers flip out. A common sound effect for this call is “centers flip out”.

This can also be done from columns or diamonds. From diamonds, the result is point-to-point diamonds. The centers must not go past each other in the very center when they flip out. It's the same issue that arises in Reverse Flip the Diamond.

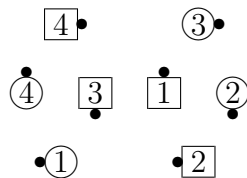

before Ends Cut In

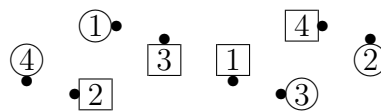

after

See [Centers Cut Out](#), page 33.

E.R.A.

This is a space-invader. Boys Press Back, while the Girls Press Ahead. This call is named after the failed Equal Rights Amendment. See [M.C.P.](#), page 97.

Erase

This is a 4-person call. Ends Isolate while the centers U-Turn Back toward each other.



before Erase

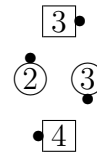

after

Explode the [Cross] Clover

Ends Cloverleaf (or Cross Cloverleaf), while the centers Trade and Roll.

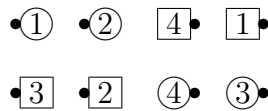

before Explode the Clover

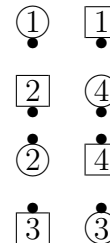

after

Explosion

From columns: #2 and #4 Press Out, and, from these fudgy 2-faced lines, do a “Slippery Couples Circulate”. “Slippery” means the very center 2 Trade as they go past.

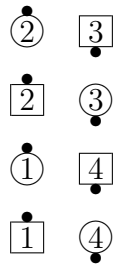

before Explosion

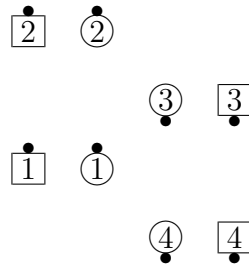

after Press Out

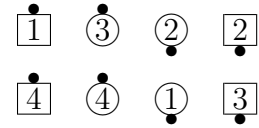

finished

Face the Music

This is used in unsymmetrical choreography. Face the caller. Of course one can also Pass the Music, Tag the Music, Shuttle the Music, Lines Walk the Music, etc.

Fall Into a Column

From a 1/4 tag: the center of the wave folds behind the end, and they move forward to become #1 and #2 of a column. The ends have someone walk and someone dodge, in the direction needed to get out of the way. From a right-handed 1/4 tag, the beau walks and the belle dodges.

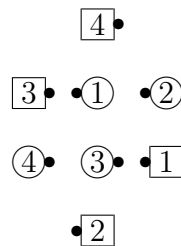

before Fall Into a Column

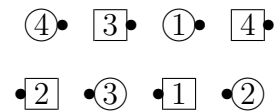

after

Fan and Cross Thru

See [Fan Thru](#), page 72.

Fan Back

See [Spin Back](#), page 143.

Fan Chain and Circulate In

See [Spin Chain and Circulate In](#), page 144.

Fan Chain and Circulate the Gears

See [Spin Chain and Circulate the Gears](#), page 144.

Fan the Gate, Fan the Gating <anything>

These are similar to Fascinate and Fascinating <anything>, and the similarity actually seems to be helpful. Usually from 2-faced lines, centers Cast 3/4 and then the center 2 cast 3/4, while the ends Circulate 1-1/2. So far, it is like Fascinate, except that the center 2 went an extra 1/4.

Now the people who would do the Concentric Wheel and Deal do a Bend the Line instead. They do not apply the Concentric rule—they stay together. The others are finished.

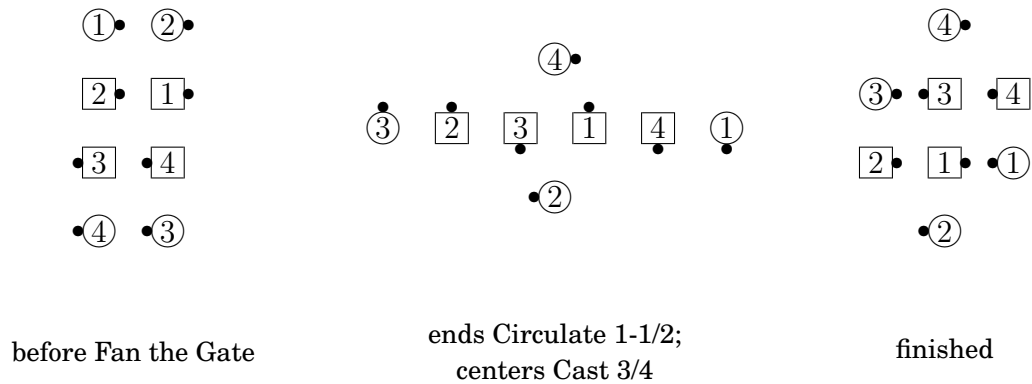

On Fan the Gating <anything>, the <anything> replaces the Bend the Line. If they finish in a 2x2, they collectively work to the elongation that they would have on Fan the Gate, that is, the opposite of what the Concentric rule would indicate.

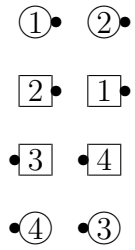

before Fan the Gating
Bounce the Boys

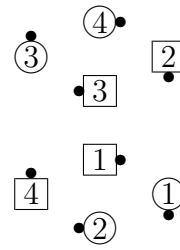

after

Fan Thru, Fan and Cross Thru

Fan Thru is Touch, Slip, and Step Thru. All done smoothly, of course.

Fan and Cross Thru is “Fan Thru Like a Cross Trail Thru”. That is, Half Sashay after the Step Thru.

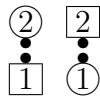

before Fan and Cross Thru

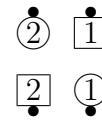

after

Ferris Trade and Wheel

This is a Ferris Wheel, but the original trailing centers, when they meet in the middle, Trade with each other before finishing.

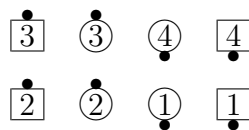

before Ferris Trade and Wheel

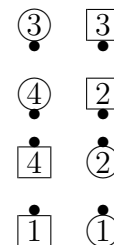

after

Fiddle Around

Straight Fire like a Couple Up. This call predates Straight Fire.

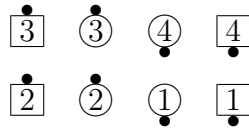

before Fiddle Around

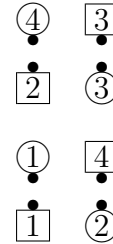

after

<anyone> **Finish the Stack**

This is the final “some people cross over and take right hands” part of Stack the Line.

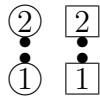

before Girls Finish the Stack

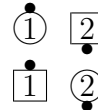

after

First Choice, First <anything>

From waves: leads Switch “With the Flow”, while the trailers extend and Lock the Hinge. On First <anything>, the <anything> replaces the Lock the Hinge.

The “With the Flow” after the Switch is the same action that is done during Keep Busy.

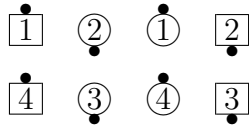

before First Reflected
Flip the Line 3/4

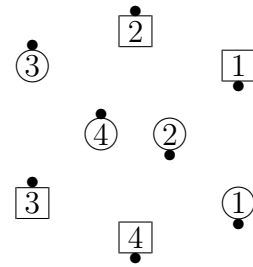

after

Flare the Star

From facing couples: all make a right-hand star, and turn it about 1/2, until the original beaus are on the other side. They leave the star by flipping away to the left and continuing to turn left until they can Courtesy Turn someone coming to them. After the original beaus have left the star, the others continue turning with each other until they are back on their original side, at which point they are Courtesy Turned.

This is a zero for the belles, and exchanges the beaus with each other. This may be a useful check when doing the call with a lot of phantoms.

For those who require a more precise-for-challenge definition, here's one from Scott Morton: 1/2 Reverse Swap Around, Counter Rotate the Diamond 1/4, Reverse Flip the Diamond, and Chain Down the Line.

[Reverse] Flip the <formation>

In analogy with Flip the Diamond or Hourglass, in Flip the <formation> those who are far apart flip in, while the others <formation> Circulate.

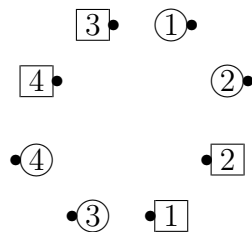

before Flip the O

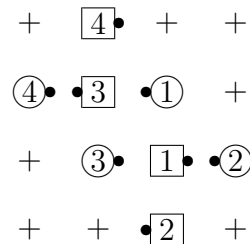

after

On Reverse Flip the <formation>, those who are close together flip away, while the others <formation> Circulate.

Flowing <anything>

With the Flow, and then **finish** the <anything> call. All of the “ing” calls (Flowing, Rolling, etc.) apply some action to the preceding call, and then let that action replace the first part of the “anything” call.

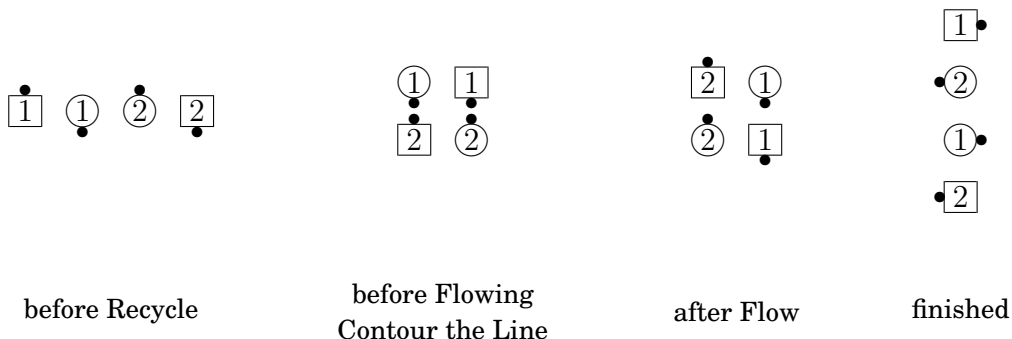

Fly Away, Fly Away and <anything>

Typically from lines with the centers facing out: centers Right Loop 1, Triple Box Circulate, and Cross Fold, while the ends Squeeze. If another call is given, and original ends do that, in the middle, after the Squeeze.

The centers effectively do a big Couples Twosome Zoom to the Right.

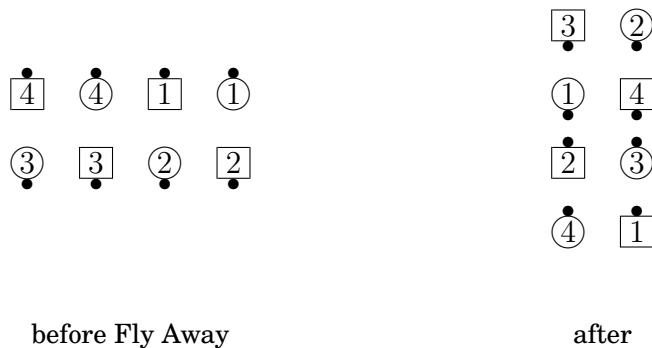

Follow and Cross, Follow and Criss Cross

The mnemonic for Follow and Cross is “Scoot Back; Eroo”. Actually, it’s a Scoot Back and Extend Eroo. Scoot Back, Extend, ends Quarter to Handhold and Circulate, and the centers Cast Off 3/4.

The mnemonic for Follow and Criss Cross is “Scoot Back; Cross Eroo”. Ignoring the fact that there is no such call as “Cross Eroo”, Scoot Back, Cross Extend, ends Quarter to original Handhold and Circulate, and the centers Cast Off 3/4. That is, the difference is that the new centers come to the opposite hand before casting

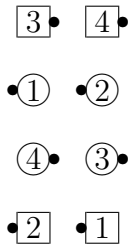

before Follow and Criss Cross

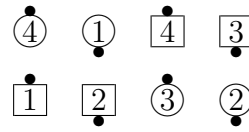

after

These calls have two parts. They originally had somewhat different definitions which were incompatible with the modern fractionalization, but no one cares.

Follow the Yellow Brick Road, Follow the Yellow Bricking <anything>

Follow Your Neighbor, Spread, Slither, centers Follow Your Neighbor and Spread while the ends circulate 1-1/2, then the couple on the end of the line of 6 Concentric Wheel and Deal while the other outside person counter rotate to become the end of the center wave.

On Follow the Yellow Bricking <anything>, the <anything> replaces the Wheel and Deal. The Concentric rule applies to it, even if that is ugly.

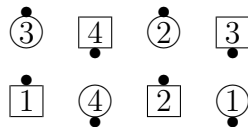

before Follow the Yellow Brick Road

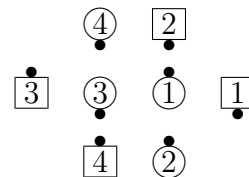

after

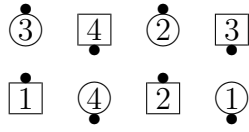

before Follow the Yellow
Bricking [1/2 Tag]

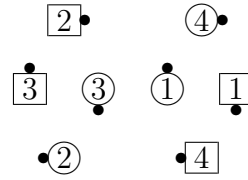

after

For a call based on a mere Plus call, this causes breakdowns surprisingly often. Think carefully about what you are doing.

[Cross] [Criss Cross] Follow to a Diamond

Cross Follow to a Diamond is like Follow to a Diamond, except that the trailers take opposite hands before Casting 3/4. On Criss Cross Follow to a Diamond the leaders additionally come to opposite hands when they meet in the center.

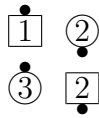

before Criss Cross
Follow to a Diamond

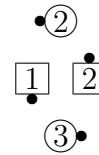

after

Follow to an Interlocked Diamond, Hourglass etc.

These are related to Follow to a Diamond. See the discussion of <ATC> to a Diamond.

Go First Class

Normally from waves: leads Switch, while the trailing end Circulates and the trailing centers Jay Walk with each other.

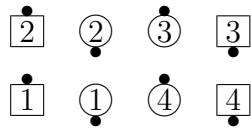

before Go First Class

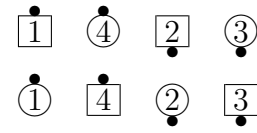

after

This bears a close similarity to Scatter Circulate, and it is useful to be aware of it. The trailers' part is the same. The leaders Switch for Go First Class and Cross Roll for Scatter Circulate. The usual setup for Go First Class is waves (going to 2-faced lines) and for Scatter Circulate it is 2-faced lines (going to waves.)

One needs to be careful when these are called from other than the usual formation, and resist the temptation simply to do the "obvious" thing. The correct result often involves collisions.

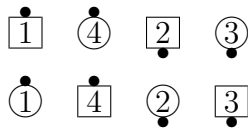

before Go First Class

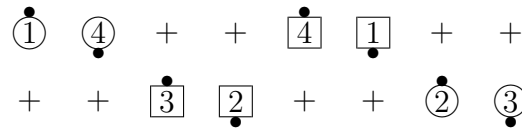

after

This can be used when some dancers are in columns. The #4 of the column is considered a "trailing end" and Circulates. The #3 of the column Jay Walks across the center.

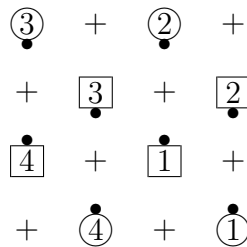

before Split Phantom Columns
Go First Class

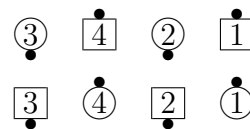

after

Grand Cross Roll

From a tidal line, the center 6 Trade and spread away from each other (as in Grand Mix), while the very ends Run. This is Grand Working as Centers Cross Roll, if that helps.

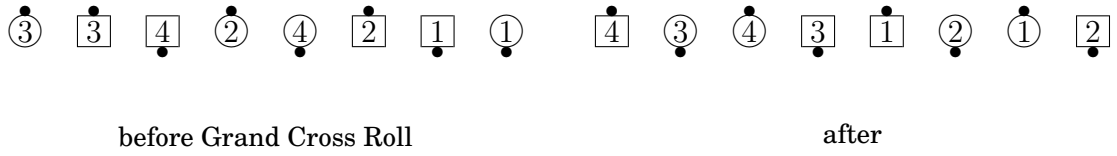

Grand Linear Cycle

This is just a Stretch Linear Cycle.

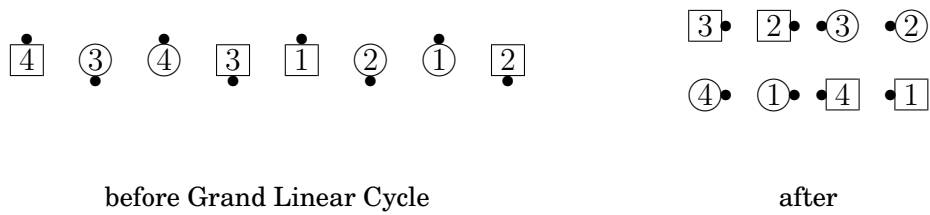

It is not useful to think of this in terms of what “grand” or “grand working” means.

Grand Run Wild

Grand Cross Roll twice. Remember to re-evaluate your position after the first one.

Grand Spin the Top, Grand Fan the Top

This call is rarely used, and dates from a time when the word “Grand” was used in a rather chaotic way.

From a tidal wave: all Trade, then the center 6 Cast Off 3/4 while the very ends Isolate. They hook on to the nearest miniwave, not the center miniwave.

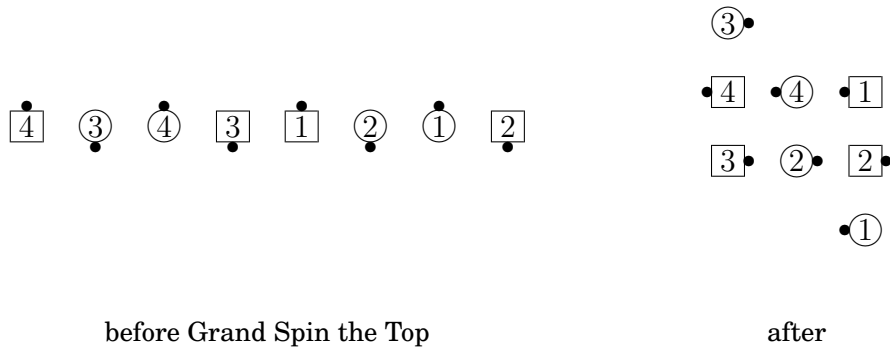

Grand Fan the Top omits the first Trade.

Grand Switch

From a tidal line, all Trade and the center 6 slide past each other in pairs. This is Grand Working as Ends Switch, if that helps.

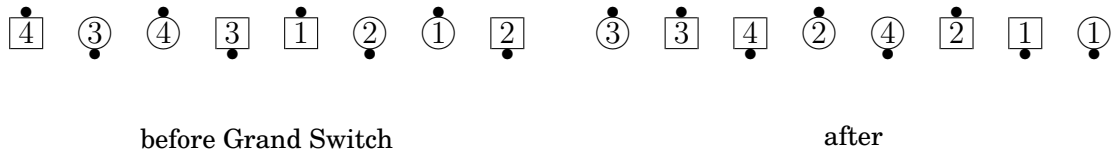

Grand Walk and Dodge

From columns: do a sort of huge Walk and Dodge—the first person dodges while the other 3 Walk, and then the centers Walk and Dodge again. The ending setup is a completed DPT. This call is horribly badly named relative to modern terminology, and is utterly obsolete.

Gravitate

From a 3/4 tag (or 1/4 tag, or whatever), the centers 2/3 Linear Cycle to become #1 and #2 of a column. The ends Reverse Single Rotate and then Split Counter Rotate to become #3 and #4.

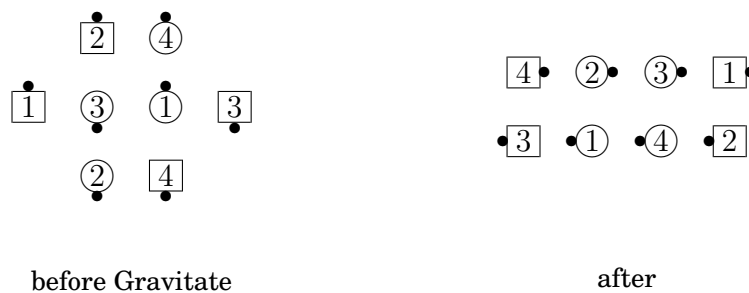

If the center wave is left-handed, a collision occurs, resulting in “clumps”.

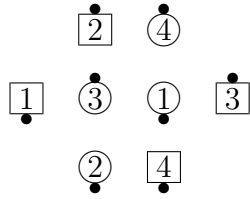

before Gravitare

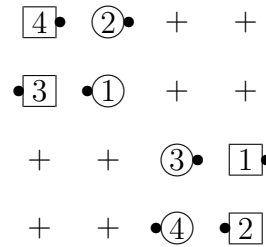

after

Hammerlane

This is a facing couples Cross Cycle.

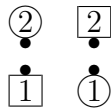

before Hammerlane

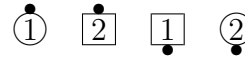

after

Hang a Right/Left

This is just “First Couple go Right/Left, next couple go likewise”.

From a completed DPT: As Couples and In Tandem Right/Left Roll to a Wave.

Hang Loose

From waves: the lead center does a cross run, while the others do a Peel and Trail in their groups of 3. The person who Peeled in the Peel and Trail then Trades with the adjacent person.

Now those who are facing Pass In. The others step forward, connect with each other, and Bend the Line. The result is facing lines.

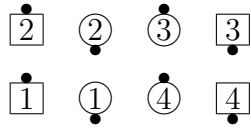

before Hang Loose

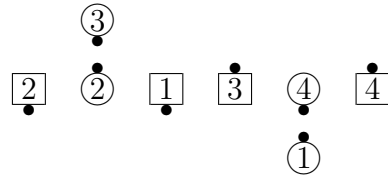

Cross Run,
Peel and Trail

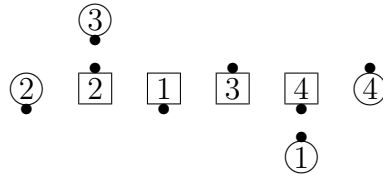

Trade

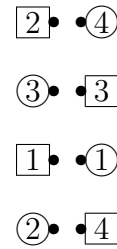

finished

Here Comes the Diamond, Here Comes the Wave

See [In Roll To a Diamond](#), page 85, or [In Roll To a Wave](#), page 86.

Hinge and Circulate <direction>

See [Single Hinge and Circulate](#), page 138.

Hinge and Trade

See [Single Hinge and Trade](#), page 138.

Hinge By $\langle M/4 \rangle \times \langle N/4 \rangle \times \dots$

This can be thought of as a sort of generalization of the Quarter Thru / Remake / Swing the Fractions calls, designed to get the maximum possible mileage out of them.

The call has as many parts as the fractions given. Each part is an Arm Turn by the given fraction, or, if necessary, a partner hinge followed by Arm Turns by the remaining amount.

It starts with everyone who can, or those designated by the caller. Subsequent turns are dictated by the requirement to alternate hands. That is, when you finish one part, you do the next with the person on the other side of you.

A given person may not be able to do certain parts, but each part must have some people in motion. Unlike calls like Swing the Fractions, there is no “right hand rule” other than the need to switch hands between parts.

The call is always “grand”. That is, it is done in the entire setup.



before Hinge By $1/4 \times 1/4$
 $\times 1/2 \times 3/4 \times 3/4$

after

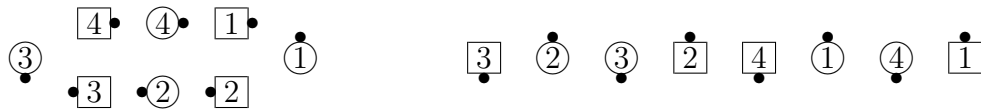

before Hinge By $1/4 \times 1/2 \times 1/2$

after

Hinge the Top, Hinge the Lock

Hinge and Fan the Top, or Hinge and Lockit.

The words Hinge, Lock, and Top (meaning Hinge, Lockit, and Fan the Top) are sometimes put together in a variety of ways, as in “Lock the Hinge the Top the Hinge the Lock” or “Transfer the Column the Lock”.

Hit the Wall

Commonly from a Trade by: centers Pass Out, ends Partner Tag.

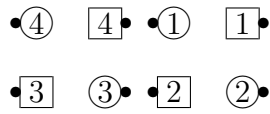

before Hit the Wall

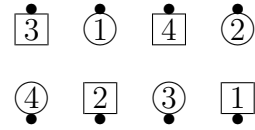

after

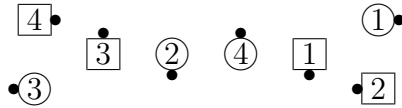

before Hit the Wall

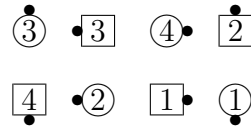

after

Hoop-De-Do

Zip Code 1, new centers take the next call; new ends Star Thru.

[Cross] <anyone> Hop

If the “Cross” modifier is given, the designated people cross over (as in Split Trade Circulate) while the others Dodge. Then everyone Hinges.

Hot Foot Spin

Fan the Top, center 2 Trade, and Spin the Top. This has 3 parts.

Hourglass Inlet, Hourglass Outlet

These are variants of Diamond Inlet and Outlet.

On an Hourglass Inlet, or Inlet to an Hourglass, the people coming in to the center do a Snake as they come in. See the discussion of <ATC> to a Diamond.

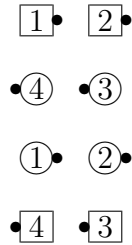

before Hourglass Inlet

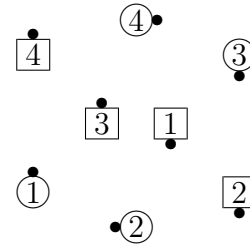

after

On an Hourglass Outlet, the center diamond does a Drop In and Hinge, fudging to the appropriate place, while the outsides do a Diamond Outlet.

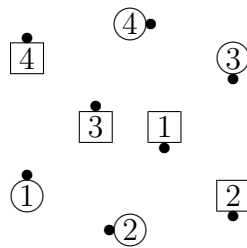

before Hourglass Outlet

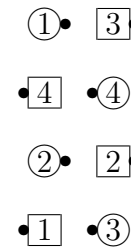

after

In Roll to a Diamond, Out Roll to a Diamond, Zoom Roll to a Diamond, Here Comes the Diamond, Sock it to the Diamond

Typically from lines: the In Roller, Judge, etc., and the person next to him, do their part of an In Roll Circulate, Here Comes the Judge, or whatever. They are now ends. The others slide into the center without turning, and then Hinge.

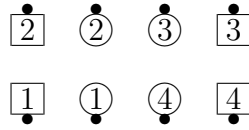

before Here Comes the Diamond

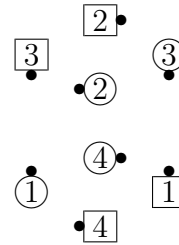

after

One can also do these calls to an hourglass or interlocked diamonds by doing the standard (Snake/Slither) adjustment.

In Roll to a Wave, Out Roll to a Wave, Zoom Roll to a Wave, Here Comes the Wave, Sock it to the Wave

Typically from diamonds: the ends do their part of an In Roll Circulate, Here Comes the Judge, or whatever. The centers slide over in the appropriate direction without turning, and then Hinge.

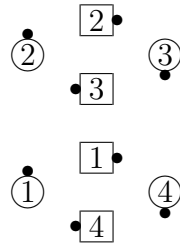

before Zoom Roll to a Wave

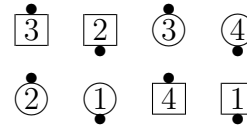

after

It would be much easier to avoid confusing these calls with the preceding ones if they were only used in the obvious formation. However, it is legal to call In Roll to a Wave from waves. The result is C1 phantoms.

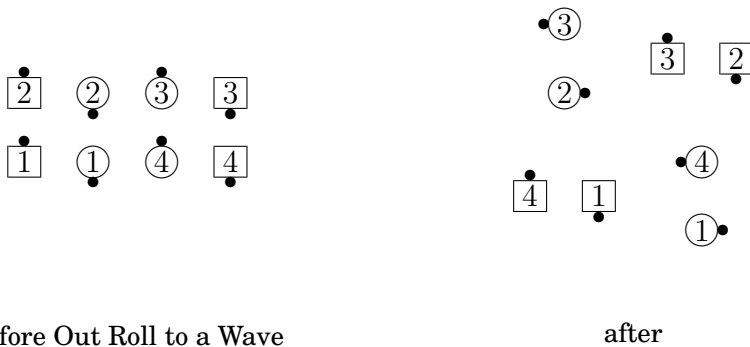

before Out Roll to a Wave

after

Inner Code

This is done only by the centers. They Quarter In, and then continue is if on a Zip Code, staying in the center. The initial Quarter In counts as 1. On an Inner Code 2, they then Pass Thru. On Inner Code 3, they then Quarter In again, etc.

See [Outer Code](#), page 101.

In Style

This is done from a formation, typically a starting DPT, in which the centers are facing or in a right-handed wave. If facing, the belle does a U-Turn Back to the right, while the beau steps up beside her. In that couple, adjust to become leads of lines, while the others (original outsides) veer or do whatever is necessary to get out of the way. It's typically a Veer Left.

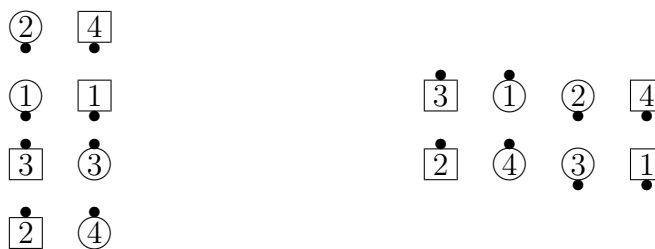

before In Style

after

If the centers are in a wave, they effectively rear back before doing it, though in fact it is rather like a Short Cycle without the final Couples Hinge.

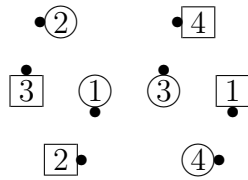

before In Style

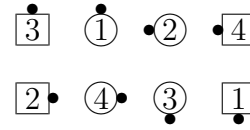

after

Interlocked Scoot Chain Thru

The usual traffic pattern on Interlocked Scoot Back is to do a Couples Twosome Scoot Back, which is probably not theoretically correct. On Interlocked Scoot Chain Thru, it is necessary to use the “correct” traffic pattern. Do a “Stretched 1/4 Tag Extend”, resulting in parallel waves. Do the usual Swing, Slip, and Swing, and then a Stretch Extend, resulting in a 2-faced line in the center.

Isolate

This is not generally used as a call in its own right. It is used in the definition of other calls (Along, Stimulate), and callers may direct specific people to Isolate.

It is the ends’ part of Lockit or Fan the Top.

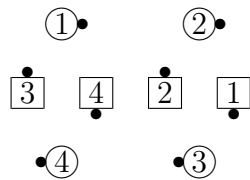

before Side Girls Isolate

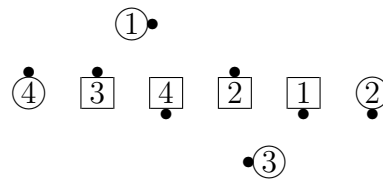

after

Jam Thru

From an 8 chain: all Pass Thru. Then the new centers Pass Thru, 1/4 In, and Pass Thru, while the ends Cross Cloverleaf.

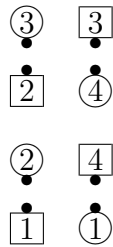

before Jam Thru

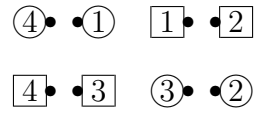

after

<anyone> Kick By <N>

The designated people do a Kickoff around N people, that is, Run around them and Roll, and each of those people tags toward the vacated spot.

Kick the Habit

Ends Counter Rotate, while, in the center, the leads Kickoff. The determination of leads and trailers for the Kickoff is made relative to the center box

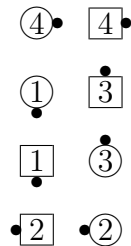

before Kick the Habit

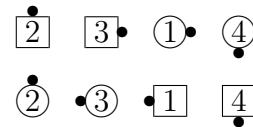

after

Lead the Class

From waves: Leads do a Follow Your Leader. Trailers Extend, Recycle, Plus 2, and face back into the center. Finishes in a DPT.

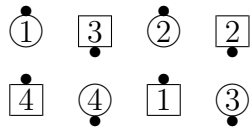

before Lead the Class

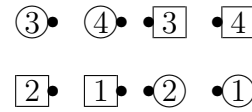

after

Lead the Way

Usually from columns: Ends Trade and Roll. Centers Peel Off and Bend the Line.

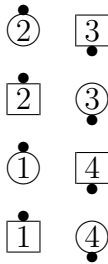

before Lead the Way

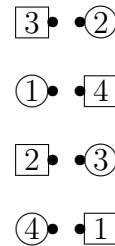

after

Left and Right Thru

Mirror Right and Left Thru.

Left On

See [Right On](#), page 118.

Lift Off but <anything>

The <anything> replaces the final Couples Circulate.

Like a Rigger

Do the final adjustment of the “Rigger” concept. The outer people of a Parallelogram or offset setup center themselves.



before Like a Rigger

after

Linear Action but Cross it

This is a Linear Action in which the center line does a Slither just prior to the Cast Off 3/4. That Cast Off is therefore typically “pushy”.

Linear Flow [but Cross it] [but Criss Cross it]

This is essentially a Flipper’s Flow, but it has the behavior of Linear cycle if the starting setup isn’t waves. All Hinge. Leads Fold. Walk forward to the 1/2 tag position, using the Linear Cycle shoulder passing rule. Then:

Linear Flow: Tandem trade

Linear Flow but Cross it: Tandem Cross Roll

Linear Flow but Criss Cross it: Tandem Trade the Wave

Then, in all 3 cases, do a (normal, not tandem) Slip.

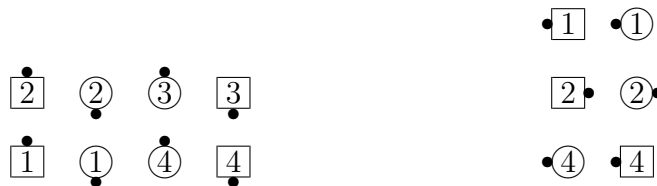

before Linear Flow
but Criss Cross it

after

Linear Flow was originally defined as Linear Cycle With The Flow, and Slip.

Lines Walk <direction>

This is typically Lines Walk In or Lines Walk Out, and is typically called from facing lines. The ends Pass Thru and step ahead, and then all face the indicated direction and adjust to lines. The centers must resist the temptation to Pass Thru with each other. On a Lines Walk In, the ends' part is a Pass Thru and Ends Bend.

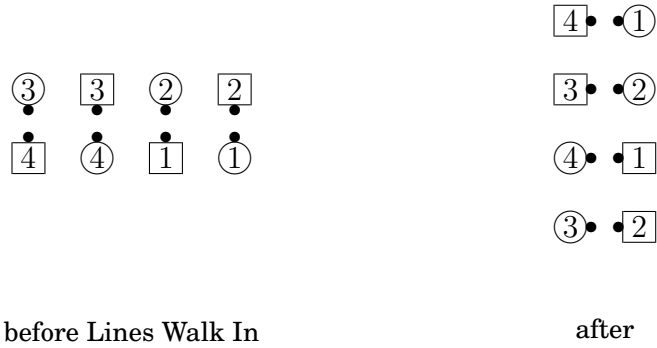

[Cross] Lock 'em Up

All Lock the Hinge (Lockit and Hinge). Then the centers Hinge the Lock while the ends Counter rotate and Roll. This has 4 parts.

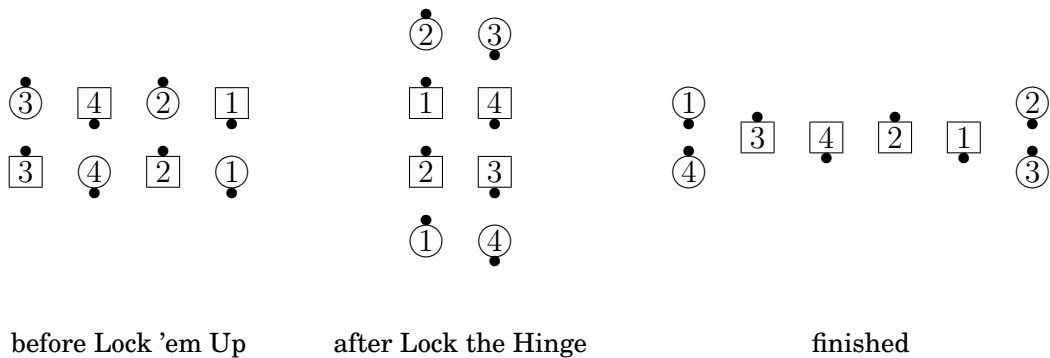
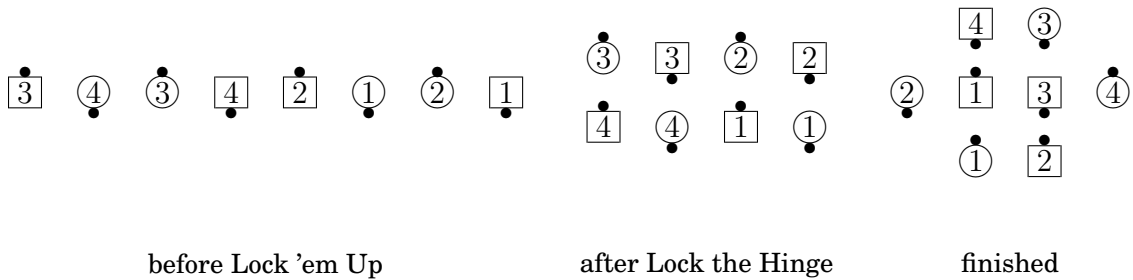

One may also hear “Cross Lock ’em Up”, “Fan ’em Up”, or “<anything> ’em Up”, in which the initial Lockit (and only that one) is replaced with Cross Lockit, Fan the Top, or whatever.

Lock ’em Up is now on the C3B list.

Long Trip

First, do a Short Trip, which see. The setup at this point is typically a parallelogram. Then the “centers” (that is, the center box) Pass Thru, while the “ends” (that is, the “wings”) Cross Fold.

Having the “wings” Cross Fold, essentially a natural Turn and Deal, is a variation that one sometimes hears in other contexts.

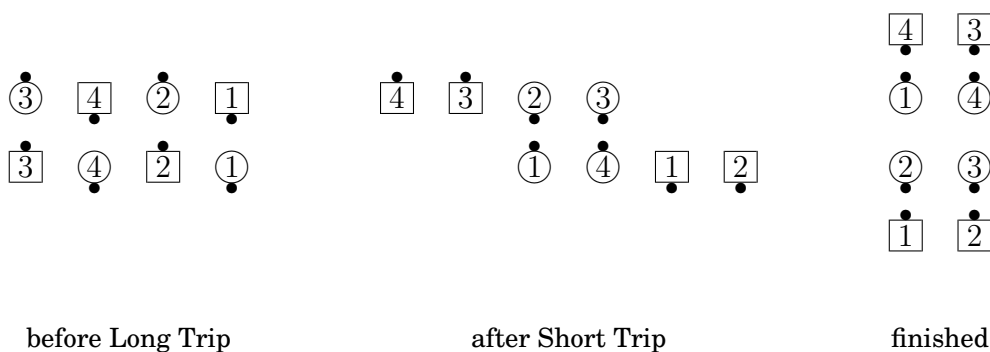

Magic In Roll Circulate, Out Roll Circulate, Zoom Roll Circulate, Here Comes the Judge, Sock it to Me

The application of the “magic” concept to these calls is quite difficult. The person doing the special action (in roller, zoomer, judge, etc.) does the action normally. The other people in the same magic line as that person flip toward that end of the magic line, staying in that magic line.

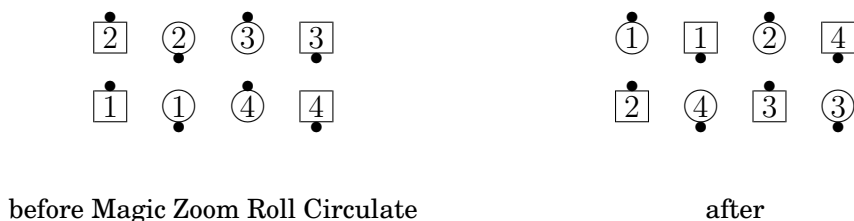

Because the magic line is hard to see, especially when everyone is running around, the following cheat might be helpful:

If you are the designated person: Just do the action normally.

If you are standing next to the designated person: Do a normal Slip. Really? Really.

Anyone else: Do a Split Counter Rotate 1/2.

[Cross] Make a Pass, [Cross] Make a Pass but <anything>

Usually from a 1/4 tag: those facing directly Pass Thru. Then the centers Cast Off 3/4 while the ends Trade and Roll.

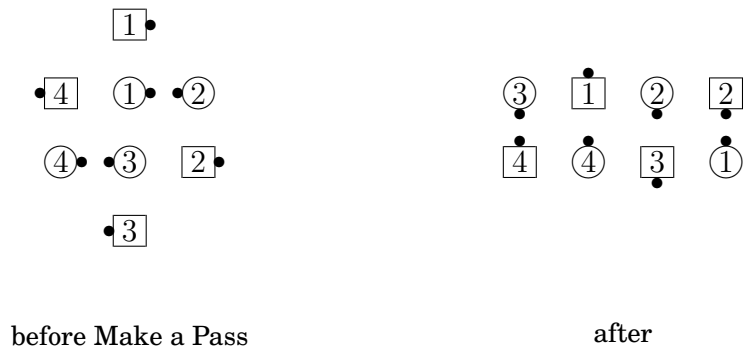
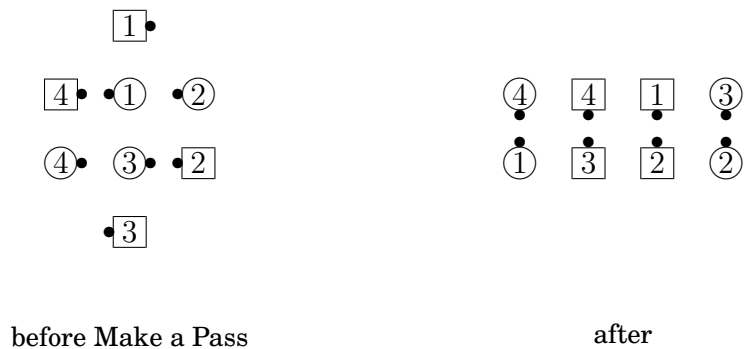

The "Cross" modifier has the same meaning as for Chain Reaction—the initial Pass Thru is diagonal.

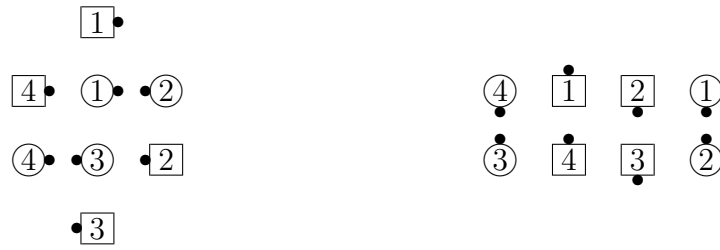

before Cross Make a Pass

after

On [Cross] Make a Pass but <anything>, the call replaces the centers' Cast Off 3/4.



before Make a Pass
but Turn and Deal

after

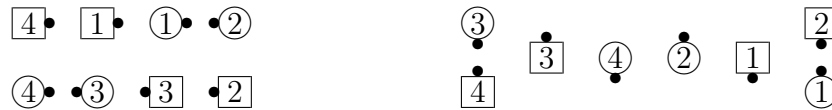

before Make a Pass
but Fan the Top

after

<anyone> **Mark Time, Mark Time**

Typically from a completed DPT, the designated people Run. The others Partner Tag instead of sliding over. The designees then Column Circulate into a box in the center, and Trade and Roll. Those who tagged do a Wheel and Deal.

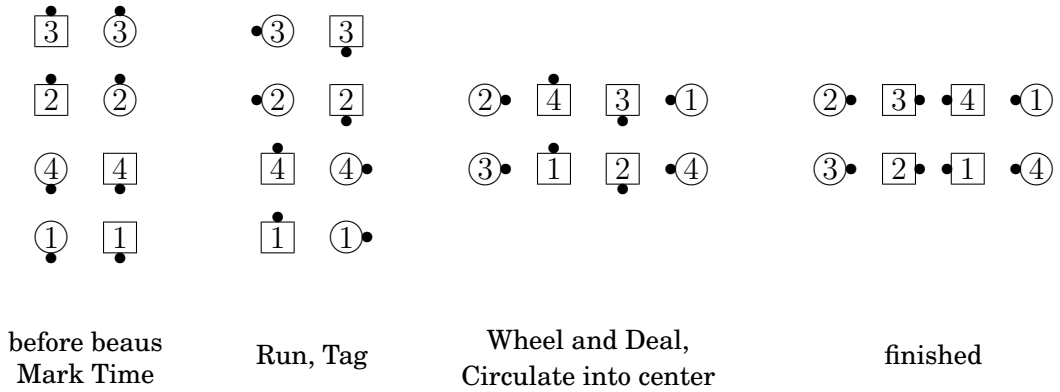

The designated people must have been #1 and #2 in the column. The others could have been facing either way. If the starting setup is columns, there is only one way to do the call, and this can be called simply Mark Time.

One can also do a Split Mark Time:

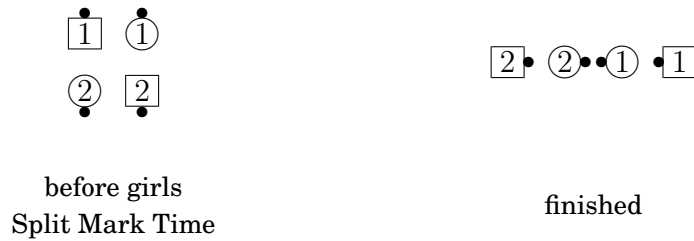

Although it is done in a 2x2, this may also be called Single Mark Time.

Mayday <direction>

From back-to-back lines: All Right Roll The. In the resulting diamonds, the center wave does a Swing Thru, while the points do their part of a 6x2 Acey Deucey. The lead point, after the 6x2 Acey Deucey, will be the end of a line of 6. After the Swing Thru is finished, everyone in the line of 6 steps forward and adjusts to lines. The trailing point of the diamond Quarters in the indicated direction and adjusts into the corner of the 2x4.



M.C.P.

This is a space-invader. Boys Press Ahead, while the Girls Press Back. This call is named after the taunt “Male Chauvinist Pig”. See [E.R.A.](#), page 69.

Mesh

This is a 2-person call, typically done from a tandem. The trailer steps forward to the right side of the other person, with the usual breathing.



This can also be done from facing people, in which case it is simply a Left Touch.

[Cross] Mini Pleasure

From columns: #1 Peel while the other 6 Extend and Trade (like Double Your Pleasure so far.) Then the center 2 spread apart, and the person who did the Peel does a Press In into that center space. The end looking out does a U-Turn Back.

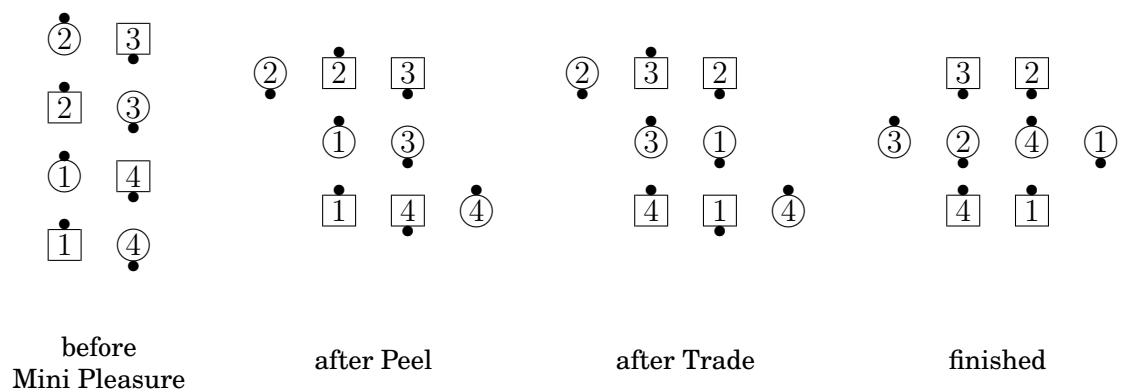

On a Cross Mini Pleasure, the #1 of the column does a Trail instead of a Peel.

<anyone> *Mix and Mingle*

This is typically done from a promenade. The designated couple does a Bend the Line to face each other, while the others get behind them. As with all calls from a promenade, people need to be careful to adjust to a nice setup.

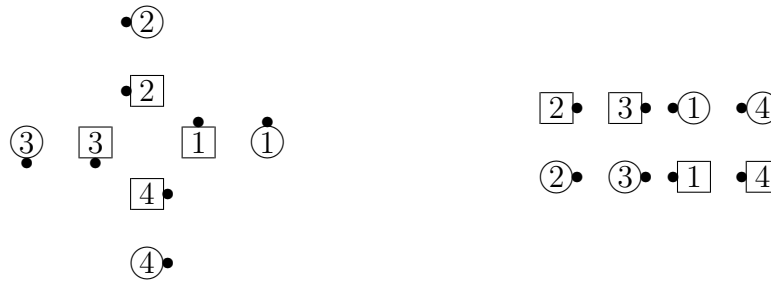

before heads mix and mingle

after

Mix the Deal

Concentric Wheel and Deal.

Mix the Deucey

This is Mix and Acey Deucey.

Mix the Turn and Deal

Concentric Turn and Deal, **but** the outside Turn and Deal is always “natural”. The center Turn and Deal is the standard right-shoulder variety.

Mix the Line

From facing lines: As Couples Quarter Out, and put the original belle-side couple in front of the other couple.

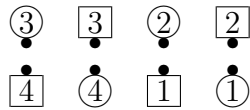

before Mix the Line

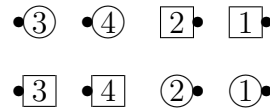

after

You could think of this as [Retreat the Line](#) (page 115) and [Shuffle the Deck](#) (page 136).

Mixed Up Square Thru, Mixed Up <anything>

The exact words used to deliver this call were never standardized. The phrase “Square Thru” might or might not be used.

Everyone start a Square Thru. Original centers go either 2 or 3 hands, depending on the starting formation, until they are ends of lines looking out. They are finished. Original ends do likewise, but instead of the last hand (they should be as if centers of facing lines at this point) they take the <anything> call. That call is often a Square Thru of some additional number of hands. They start that Square Thru with their available hand.

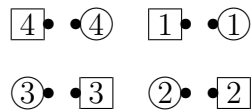

before Mixed up Square Thru,
new centers go 3 more hands

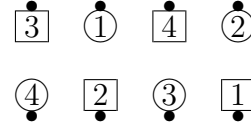

after

Nice and Easy

Typically from waves: centers Trade and Roll; ends Zing.

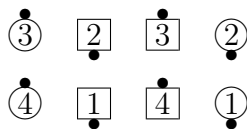

before Nice and Easy

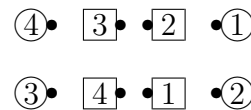

after

Nicely

Hinge and Cross.

Nightmare

See <ATC> er's [Dream/Nightmare](#), page 16.

Nip and Tuck

This starts in back-to-back couples. The widely accepted “cheat” for this is Couples Twosome Latch On. The precise definition, essentially indistinguishable from the “cheat”, is: belles “3/4 Zoom”, while the beaus Run and Wheel Thru. “3/4 Zoom” is not actually a call. Think of it as a 3/4 Stable Zoom, or Shakedown, or Zing, if you prefer.

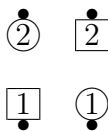

before Nip and Tuck

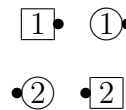

after

Open Ups <anything>

This is analogous to Trans <anything>. Open Up and Nothing, centers Cast Off 3/4, and then do the <anything>.

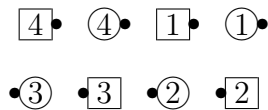

before Open Ups Nuclear Reaction

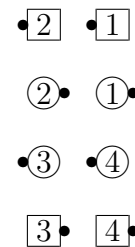

after

[Left] [Twin] Orbit Circulate

These are done from waves and are similar to Trade Circulate. The leader on the right does a “Cross Over Zoom”, using a slightly wider path than usual. Whatever the handedness of the wave, he goes to the spot behind him, turning 360 degrees, and spread from center to end or end to center. The other 6 do their part of a Trade Circulate.

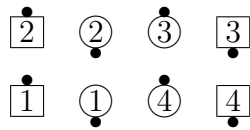

before Orbit Circulate

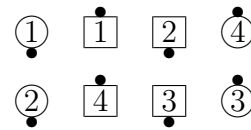

after

On a Left Orbit Circulate, the leader on the left does the “Cross Over Zoom”.

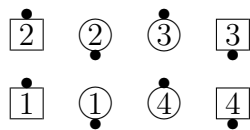

before Left Orbit Circulate

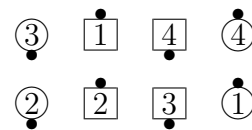

after

On a Twin Orbit Circulate, all the leads do the Zoom, carefully.

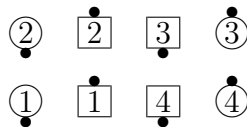

before Twin Orbit Circulate

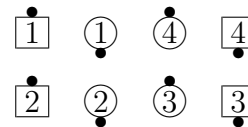

after

Out Roll to a Diamond, Out Roll to a Wave

See [In Roll To a Diamond](#), page 85, or [In Roll To a Wave](#), page 86.

Outer Code

This is done only by the outsides, and they must be as if in columns. They Quarter In, and then continue is if on a Zip Code. The initial Quarter In counts as 1. On an Outer Code 2, they then Pass

Thru. On Outer Code 3, they then do an Ends Bend, etc.

See [Inner Code](#), page 87.

Outpost

This starts in lines with at least one end looking out. Do 1/2 of an Out Roll Circulate if one end is looking out, or 1/2 of a Here Comes the Judge if both ends are looking out. Then the center 6 Trade. Then the center wave Ah So while the ends do 2 O Circulates.

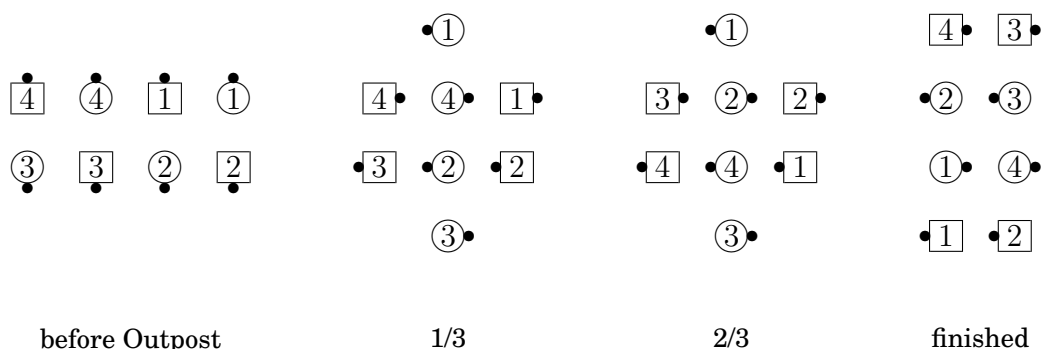

This call has 3 parts. The 2 O Circulates count as a single part.

Since the first part can be difficult, good teamwork is important. If you are a lead on the right end of the line (a “judge”), say so. If you are a lead on the left end of the line (a “socketer”), look at the other end of the line, make a decision, and make sure everyone knows what is happening.

This call is often used to put people’s knowledge of “finish” and “like a” to the test. “Finish Outpost” is the last 2/3. “Like an Outpost” is the last 1/3.

[Cross] Pair the Line

Centers U-Turn Back while the ends Fold.

On a Cross Pair the Line, the centers Trade while ends Cross Fold.

The Fold makes this a semi-space-invader. Breathing takes place laterally (relative to the Fold), but not front-to-back.

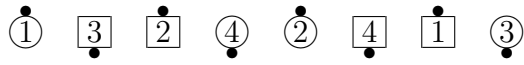

before Pair the Line

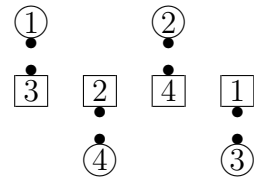

after

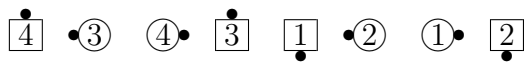

before Pair the Line

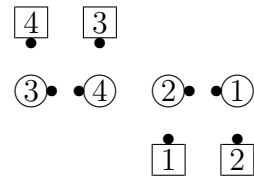

after

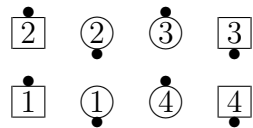

before Cross Pair the Line

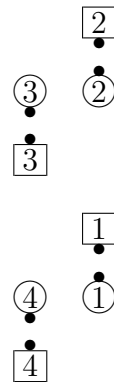

after

Pass and Roll the Axle

Do the first 3/4 of a Pass and Roll, and then do The Axle.

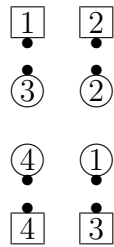

before Pass and Roll the Axle

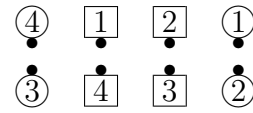

after

Pass and Roll the Yellow Brick Road

Pass and Roll the Yellow Bricking <anything>

Pass and Roll Your Neighbor, but turn the Follow Your Neighbor into a Follow the Yellow Brick Road or Follow the Yellow Bricking <anything>.

Pass and Roll Your [Cross] [Criss Cross] Neighbor

Like Pass and Roll Your Neighbor, but do the appropriate Neighbor call.

Pass the Top

From facing lines: Centers Spin the Top, Explode, and spread apart. The ends Pass Thru, Bend the Line, Pass In, and step forward into the space that has just been vacated.

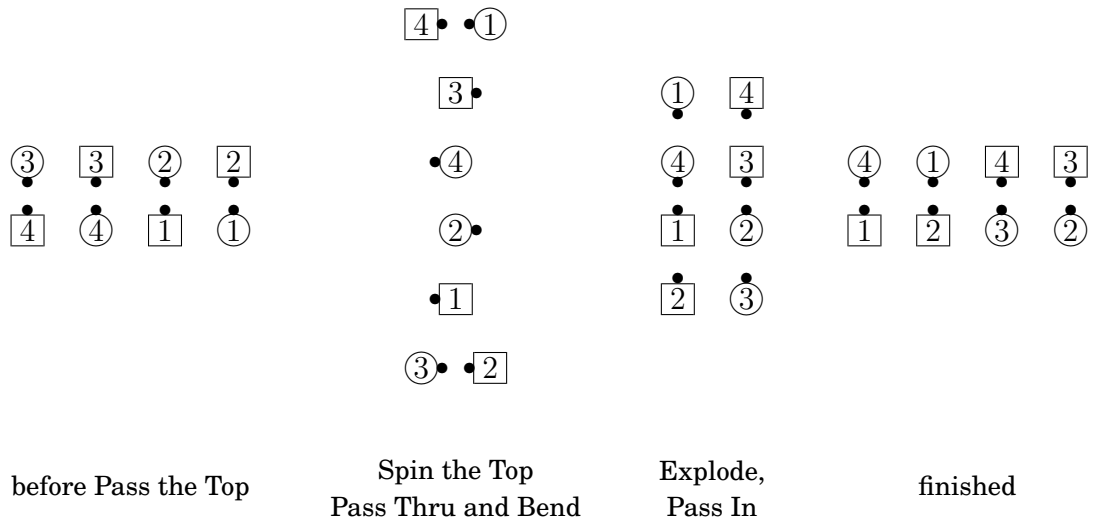

Pass to the Outside

In analogy with Pass to the Center, Pass Thru and the new **centers** Trade.

Peel the Deal, Trail the Deal, etc.

Peel the Deal is just Loop and Tag Zero. Trail the Deal is just Cross Loop and Tag Zero.



On Peel and Trail the Deal, the leads do their part of Peel the Deal, while the trailers do their part of trail the deal. The traffic pattern on this is sometimes puzzling.



Peel the Wave, Trail the Wave

See [Clover the Wave](#), page 42.

<anyone> PinWheel

This is typically done from a promenade. The designated couple does a Cast Off 3/4 to finish as the outsides of a starting DPT. The others Wheel and Deal to become the centers. As with all calls from a promenade, people need to be careful to adjust to a nice setup.

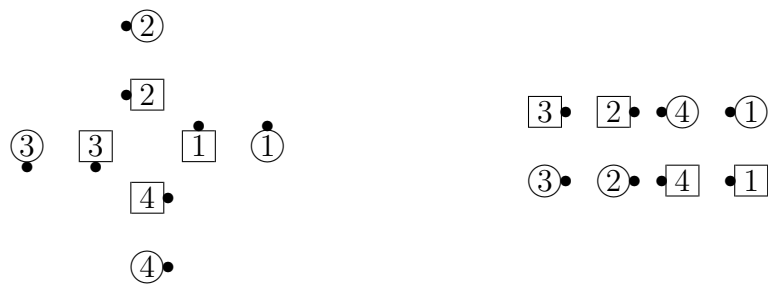

before Heads Pinwheel

after

One can also do this from other formations, such as a tidal line. The designated people Cast Off 3/4 and finish on the outside, while the others Wheel and Deal. The non-designees need to remember that they are involved.

Pitch <direction>

This is normally done from a tandem of two people, though facing people or back-to-back people can do it, with everyone doing their part. The leads do a “3/4 Zoom” to the right, like a Latch On or the belles part of Shakedown, while the trailers Circulate forward and face in the indicated direction. If no direction is given, they do not turn.

To make things more exciting, the caller can say “Left Pitch”, in which case the leads go to the left, but the trailers still turn in the unmodified stated direction, that is, the initial “left” applies only to the leads. “Left Pitch Left” is the mirror image of “Pitch Right”.

Plus <N>

After any call that has a natural veering or sweeping direction, everyone slides laterally in that direction that number of **half** matrix spots. Plus 2 has people sliding one position.

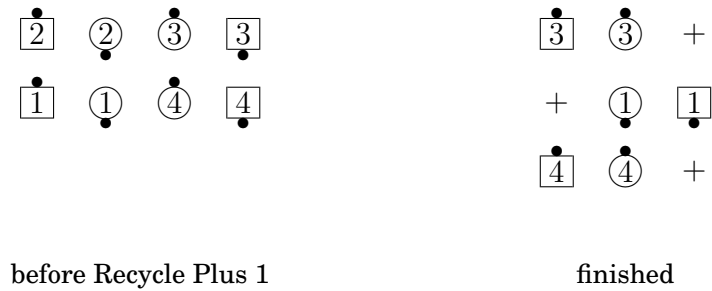
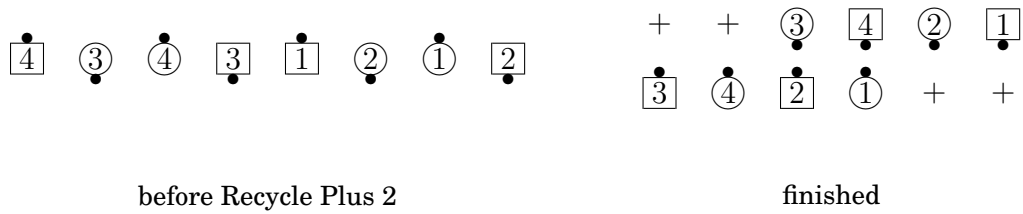

Pop

Explode the Wave. See [Snap, Crackle, and Pop](#), page 141.

Press for Time

From columns: #3 and #4 Press Out, while #1 and #2 phantom Run and Circulate. (The latter part is somewhat similar to the start of Mark Time.)

The part for #1 and #2 is often confusing. There is a trick that most people use—It happens that everyone finishes next to the same person they started with. So the #3 and #4 dancers (who, it seems, have an easier part), give a slight tug with their hand to the person next to them, sort of as though they were doing a Shove Off.

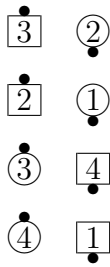

before Press for Time

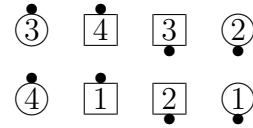

after

Presto

From 2-faced lines: centers Scoot Back and Press Ahead to become #1 and #2 of columns. Ends do a Tandem Cross Fold to become #3 and #4.

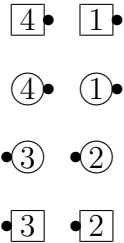

before Presto

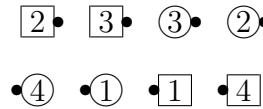

after

If done from waves, a collision occurs, resulting in “clumps”.

Push Off

Zip Code 1. Then the new ends Touch 3/4 while the new centers Fan the Top and Hinge.

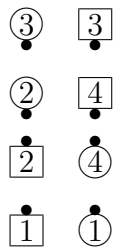

before Push Off

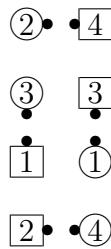

after Zip Code

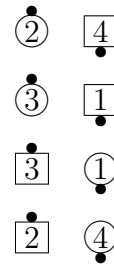

finished

Because Fan The Top is flexible, Push Off is flexible.

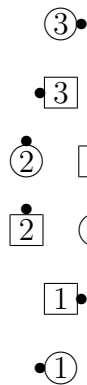

before Push Off

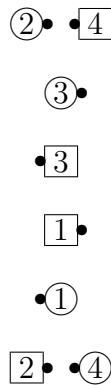

after Zip Code

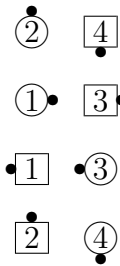

finished

Push Open the Gate

From an 8 chain or inverted lines: Put Centers In if necessary. All Cast Off 3/4. Centers Pass Thru while the ends Bend and Slide Thru.

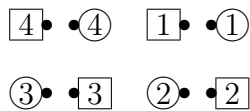

before Push Open the Gate

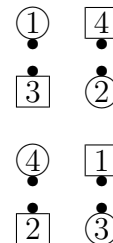

after

Quick Change

This is essentially an Acey Deucey and Face In. The precise definition is: Ends Circulate and Face in, while the centers Trade and Roll.

Quick Wrap

From columns: #1 and #2 Split Counter Rotate, while #3 and #4 Circulate into the center and then Reset 1/2 (new #2 roll outward to meet the new #3, and then they Hinge).

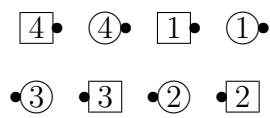

before Quick Wrap

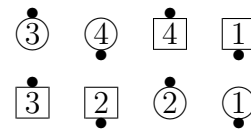

after

If “magic” is used, the Circulate for #3 and #4 is magic, and the #1 and #2 do a “Magic Split Counter Rotate” (not a real call)—#1 Split Counter Rotates while #2 Magic Circulates and faces in.

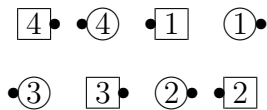

before Magic Quick Wrap

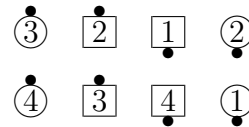

after

[Cross] Reactivate to a Diamond, Coordinate to a Diamond

On these calls, the people who Trade to become centers of the resulting lines do an extra Hinge. Usually this just turns a Cast 1/2 into a Cast 3/4, but it might be a Partner Hinge.

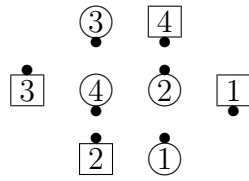

before Reactivate to a Diamond

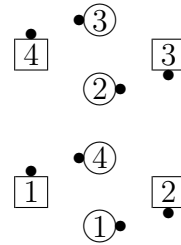

after

Reciprocate

Typically from a 3/4 tag or Trade By: centers Spin the Windmill while the ends Divide and Touch 3/4.

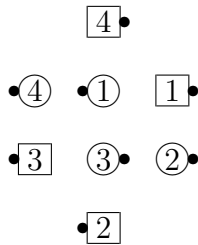

before Reciprocate

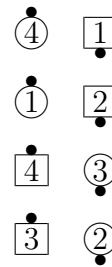

after

Recount

Usually from waves: the end looking out and the adjacent center do a 2/3 Recycle to become ends of the resulting lines. The others anchor the center for a cast 1/4 inward. Usually that cast will just be an Arm Turn.

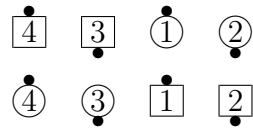

before Recount

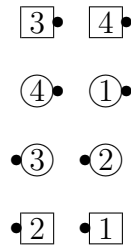

after

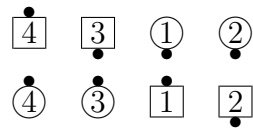

before Recount

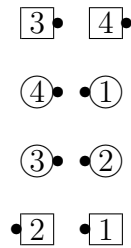

after

Relay the Diamond

Swing 1/2. Centers Cast 3/4, Slip, and Swing, while the ends Circulate 2 positions. Now there are diamonds. Diamond Circulate, Then the centers Cast 3/4.

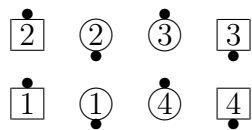

before Relay the Diamond

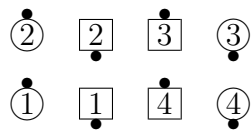

swing

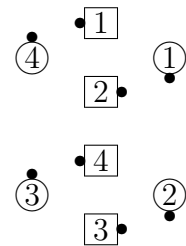

cast 3, slip, swing
Circulate twice

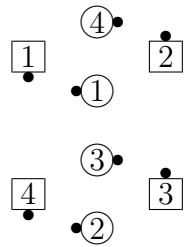

Diamond Circulate

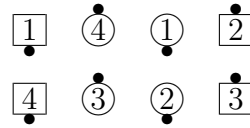

finished

Relay the Yoyo

This is an old name for what is now called Yoyo Relay the Top.

Relay Your Pleasure

From a tidal wave: All Trade. Then the center 6 Cast 3/4 while the outer 2 isolate. The center 2 then spread apart. The people who Isolated press into the space that was created in the very center. The other people who are looking out U-Turn Back.

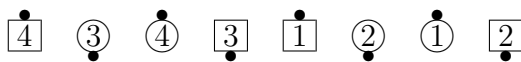

before Relay Your Pleasure

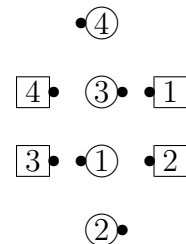

after

Remember the Alamo

From waves: Outer actives (end looking out and adjacent center), Ah So, while the others Split Counter Rotate. Result is an Alamo Ring.



before Remember the Alamo

after

[Cross] Replace the Column [but <anything>]

This could be defined in a geometrically accurate way as Invert the Column 1/2, then the ends Counter Rotate while the centers Reset 1/4 and 2/3 Recycle.

But a more useful definition starts with Invert the Column 3/4. Then, of the outer columns of 3, the first 2 continue Counter Rotate to become ends of lines, while the last one moves forward to be in a line with the very centers, and that line does a 2/3 Recycle.

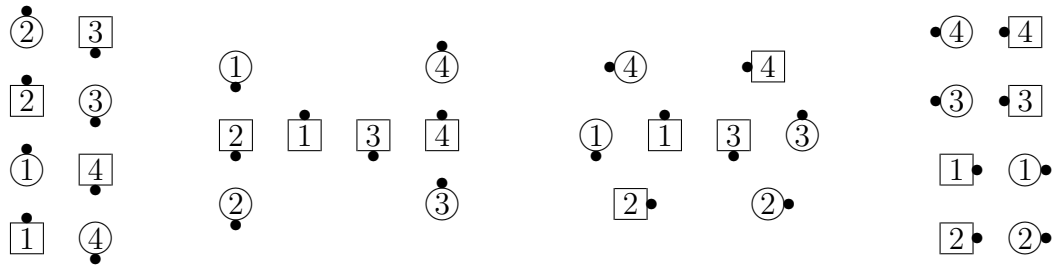

Start

Invert 3/4

first 2 Counter Rotate,
last one steps ahead

finished

The person left behind on the Invert (the original #4) must wait patiently for the last of the 3 people walking past, before doing the 2/3 Recycle. Don't grab the wrong person.

On a Cross Replace the Column, use a Cross Invert 3/4 and a 2/3 Cross Cycle.

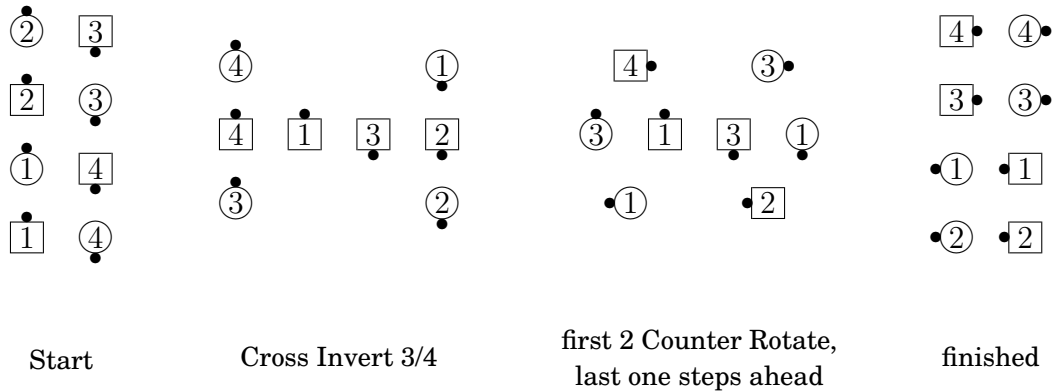

If “but <anything>” is used, that call replaces the 2/3 Recycle or 2/3 Cross Cycle.

Retreat the Line

This is a Bend the Line that goes the other way. As couples 1/4 out.

Reverse Explode

From a 1-faced line, the ends step forward, all face away from the original center of the line, and adjust to a new line.

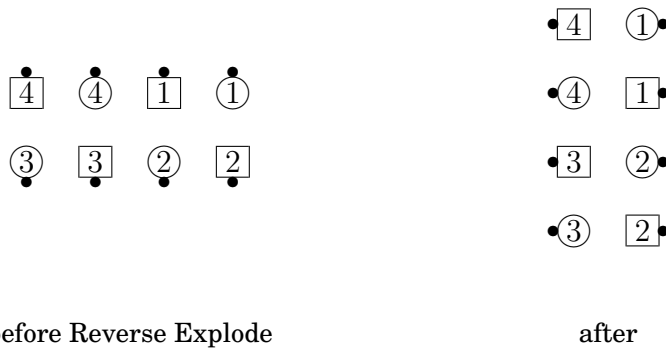

Reverse Stack the Line

Quarter In and the original **trailers** go across to right hands.

Reverse the Diamond

From Diamonds, or any formation in which the center 4 are in a wave: Centers Trade the Wave while the ends U-Turn Back.

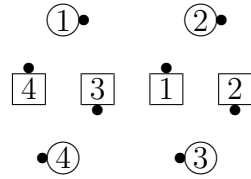

before Reverse the Diamond

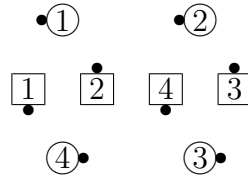

after

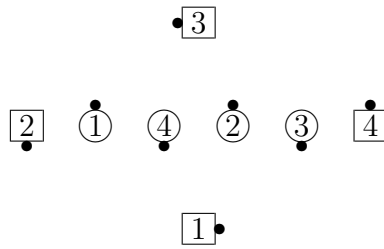

before Reverse the Diamond

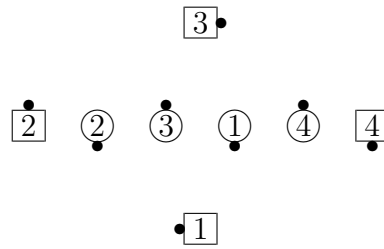

after

Ride the Tide

From an 8 chain: all Cross Trail Thru. Clover and Square Thru 2. Slide Thru.

This has 3 parts.

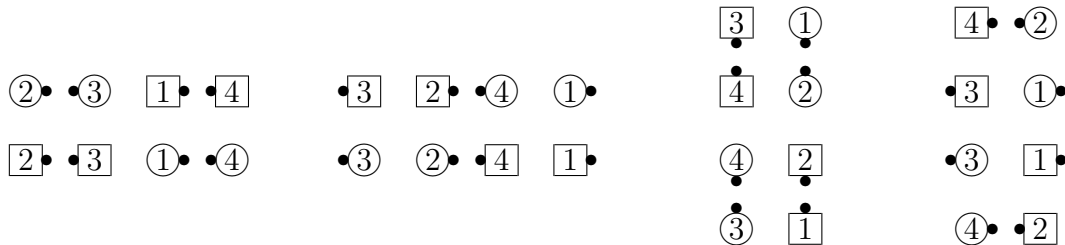

before Ride
the Tide

Cross Trail Thru

Clover and
Square Thru 2

finished

For the original centers, the Cross Trail Thru and Cloverleaf feels a lot like the Pass Thru and Cross Cloverleaf of Jam Thru. But, if fractionalized (e.g. Finish Ride the Tide), you need to be careful.

Right/Left Anchor <N/4>

This is a space-invader. As a couple, turn the indicated fraction in the indicated direction. Do it in such a way that the person toward whom you are turning (belle for Right Anchor, beau for Left Anchor) stays on the same spot. The other person does all the walking.

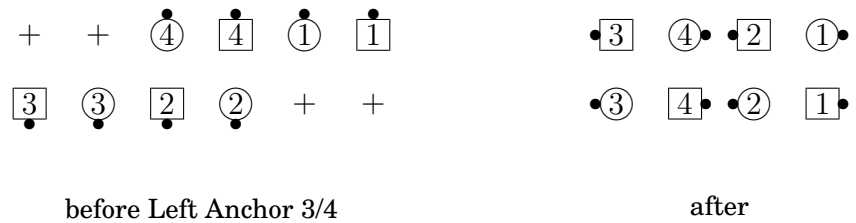
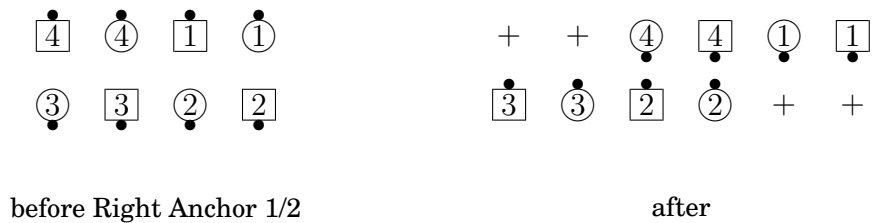

Right and Left By [By] [By]

Right and Left Thru and 1/4 More, then Slither. On Right and Left By By, follow that with a Slide. On Right and Left By By By, Follow that with another Slither.

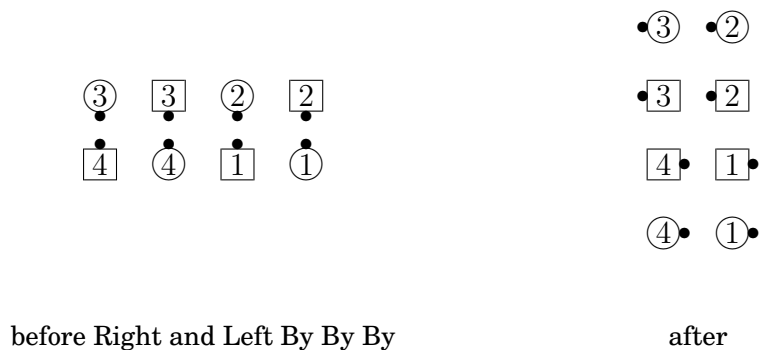

One can do the “By” action after any call that ends with a Courtesy Turn.

Right and Left Roll

Right and Left Thru and Roll.

Right On <N>, Left On <N>, Right/Left On <N> and <M/4>

Square Thru, but on the last hand Cast 3/4 and Roll. This is equivalent to not taking the last hand at all, and just standing there facing each other, which is a common cheat, flourish, or whatever you want to call it.

The mirror image of this is Left On.

When a fraction is used after the number, it means to Cast that amount instead of 3/4. It is the only known case of a phrase like “3 and a quarter” meaning something other than the number 3.25.



before Right On 3 and 1/4



after

Right Roll The

Yes, that’s the actual name of the call.

This is essentially half of a Drift Around, creating a diamond.



before Right Roll The



after

Rip Saw

From lines with the ends looking out: Ends Cross Fold, while the centers tag with each other and Cloverleaf to stand behind the original ends. The original ends are now in the center. They Pass Thru with each other, and all adjust to a 8 chain.

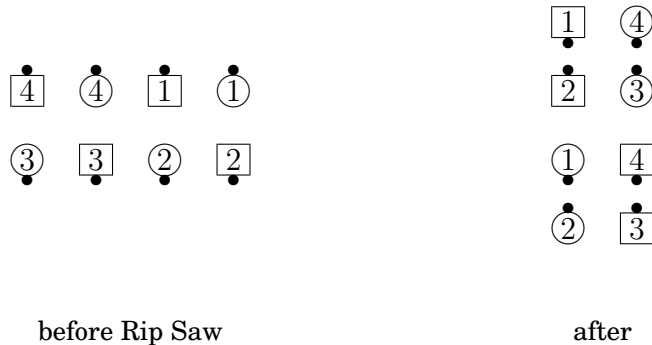

Rip the Line

Think “Pair and Cross Pair”—that is, Centers Pair the Line (U-Turn Back) while the ends Cross Pair the Line (Cross Fold).

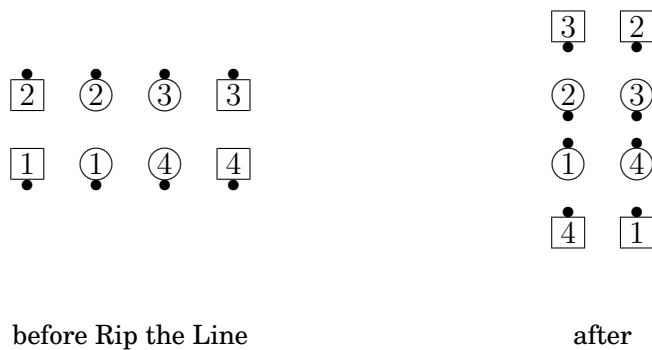

Roll Em

This is like Here Comes the Judge, but the Judge does a Zoom instead of a Circulate.

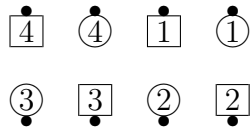

before Roll Em

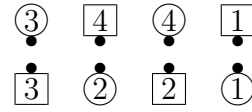

after

Rolling <anything>

Roll, and then **finish** the <anything> call. All of the “ing” calls (Flowing, Rolling, etc.) apply some action to the preceding call, and then let that action replace the first part of the “anything” call.



before Recycle



before Rolling
Contour the Line

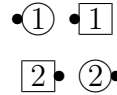

after Roll

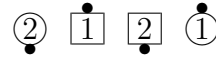

finished

Roll Out the Barrel

From back-to-back lines: the couple on the right does a Link Up and 2 Circulates. The couple on the left does a Tag the Line, Face In, and the trailers’ part of Link Up.

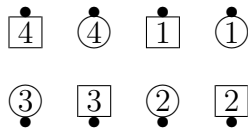

before Roll Out the Barrel

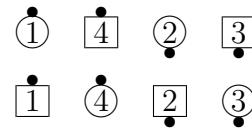

after

Confusing this with another call that has “barrel” in its name is fairly common.

Roll Out to a Column

Usually from a completed DPT: the end couple does a Right Anchor 1/4, Roll, and Press Ahead, The centers 1/4 Right, Counter Rotate, and Press Ahead.

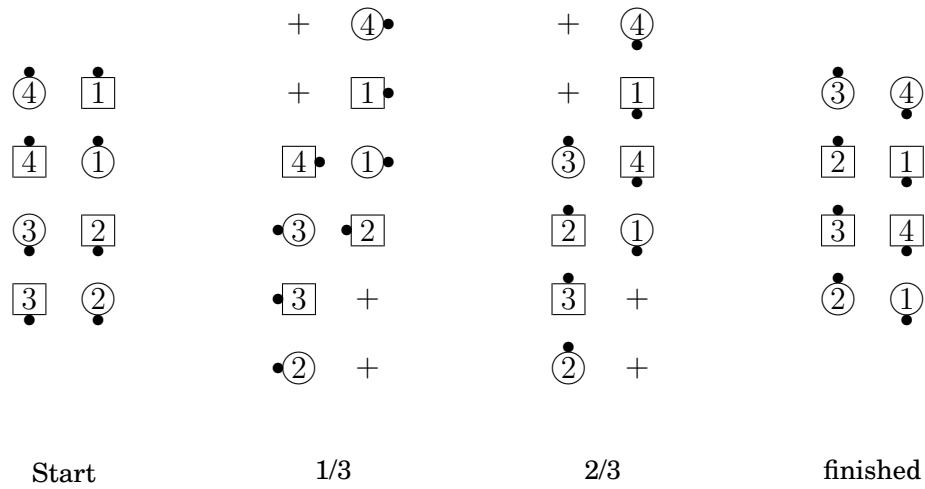

This has 3 parts. When fractionalized or called from a setup other than a completed DPT, the resulting setup might be irregular.

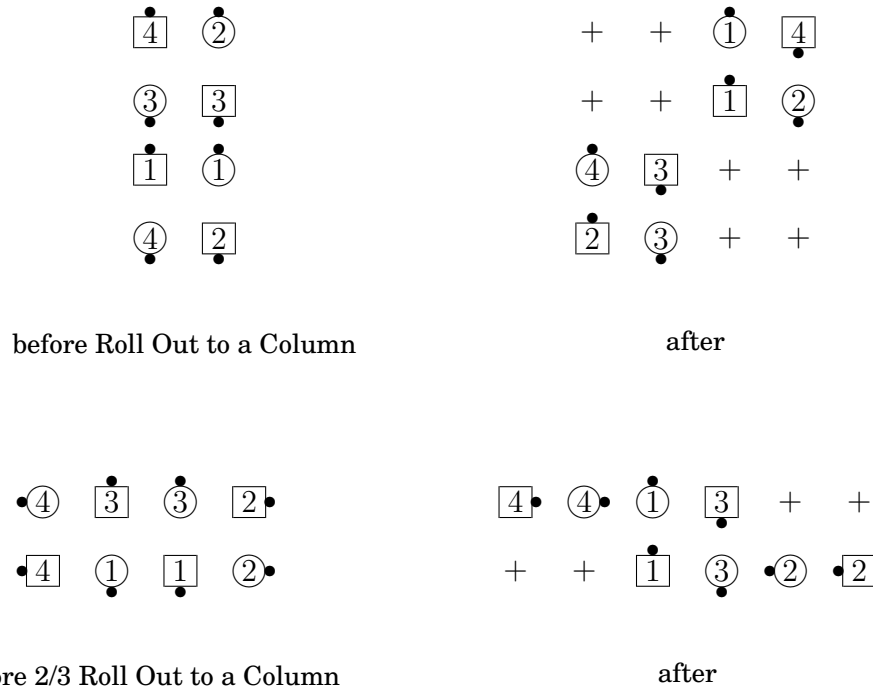

Roll the Line

From lines: Quarter away from the center of the line (“Lines Divide”), and then “Peel” **inward**, adjusting to facing lines. Some texts described it as Round Off (making it legal only from back-to-back lines) and Put Trailers Out.

The difference between this call and Roll the Wave has for some time been considered more obscure than people want to think about, and this definition is quite obsolete. In fact, this name is now applied to the definition given below for Roll the Wave. They are the same call. The difference is the same as the difference between Switch the Wave and Switch the Line—the two names are simply a verbal nicety on the part of the caller, depending on the starting setup.

Roll the Wave

From a wave or line: Quarter away from the center of the line (“Lines Divide”), and individually “Peel” in flow direction, adjusting to couples.

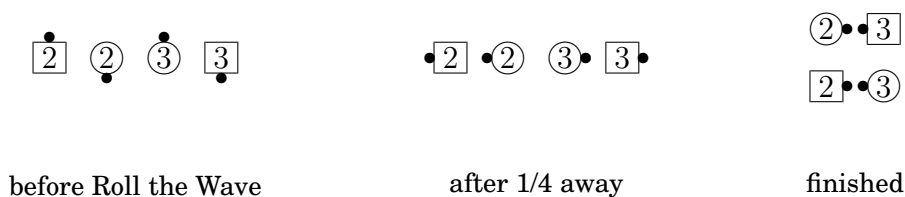

This is now also called Roll the Line when the formation is not a wave.

It may be useful to think of Roll the Line / Wave as: U-Turn Back away from the center of the wave, and then either Explode or Bend the Line, as applicable.

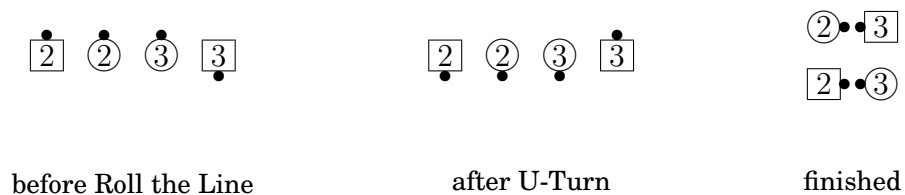

Rotary Circulate

From waves: Leads extend and 1/4 to handhold (that is, 1/2 Split Circulate), Circulate twice around the outside, and Drop In, while the trailers extend, hinge, Circulate twice in the center, hinge, and Extend or Drop In.

A little analysis will show that this is a Follow Thru, Couples Circulate twice, and natural 1/2 tag. Or Tandem Twosome Hinge, Couples Circulate twice, and Couples Twosome Hinge. Imagining that you are taking hands during the Couples Circulate (or actually doing so, though some people dislike that) may help you maintain your orientation.

This call is a Circulate variant, so one can hear things like “Rotary Percolate”. Try not to confuse this with a Rotary Spin variant such as “Rotary Mix”.

Round and Cross

This is a Round Off and everyone Half Sashay as the call completes. Everyone.

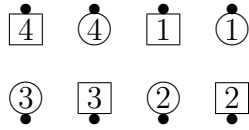

before Round and Cross

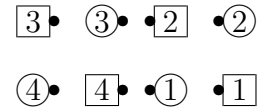

after

Round Off

From back-to-back lines: Quarter away from the center, and then Tandem U-Turn Back inward. This is done in one smooth motion. The ending feels a lot like a Cloverleaf.

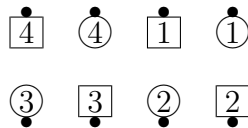

before Round Off

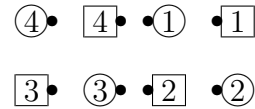

after

Round the Horn

This is like a Round Off, but those who finish in the center Pass Thru with each other. The others don't complete their turning motion (that is, do the call 1/2 Stable.) They will then be facing each other on the end. They Pass Thru with each other.

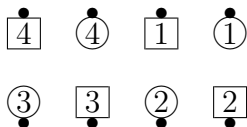

before Round the Horn

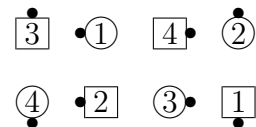

after

[Cross] Run Away

From any line: Centers Run (or Cross Run) and Roll. The others face each other across the vacated space, move forward, and Touch 1/2. The Touch 1/2 is always by the right. The call ends in a single 1/4 tag.



before Cross Run Away

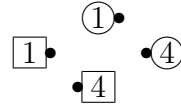

after

<anyone> Run By <N>

The designated people Run around N people, each of whom slides toward the original runner.

<anyone> [Cross] Run the Top

This is just <anyone> Run, then Fan the Top. If, after the Run, you have facing couples, the Fan the Top must be of the facing couples type.

On a Cross Run the Top, start with a Cross Run. The Fan the Top is normal.



before Girls Run the Top

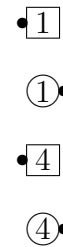

after

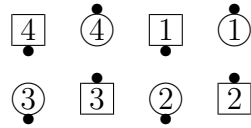

before Girls Run the Top

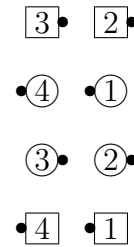

after

<anyone> Run the Wheel

From any setup in which people have partners: The designated people Run, and then do a Curve Right or Left, in the same direction in which they ran. The others Trade and Roll. The “Curve” is often described as a Wheel Thru or Left Wheel Thru, in the obvious direction.

This is a space-invader because of the “Curve”, though it is very rarely called in a way that makes use of that.

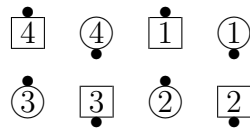

before Girls Run the Wheel

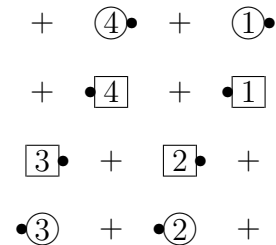

after

The interesting space-invading properties of this call are hardly ever used anymore. The call is almost always Leads Run the Wheel.

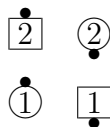

before Leads Run the Wheel

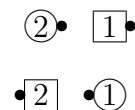

after

Run Wild

This is Cross Roll to a Wave (or Line), twice.

This call is sometimes fractionalized by quarters, which means that a Cross Roll is fractionalized by halves. When this happens, and the starting setup is a wave, the result is offset miniwaves. Remember that the definition of Cross Roll says that, when started in a wave, the original centers doing the Cross Run take the outside track. The original ends take the inside track. The halfway point is at the instant they are passing each other. The hand they take is determined by the shoulder they were passing. It is *not* a “collide and take right hands” situation.

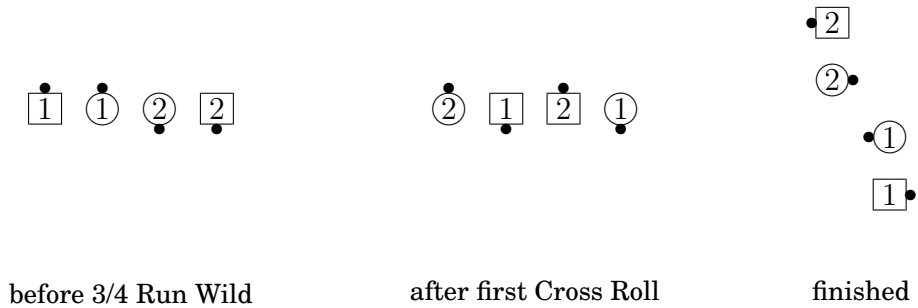

From waves, there is no problem:

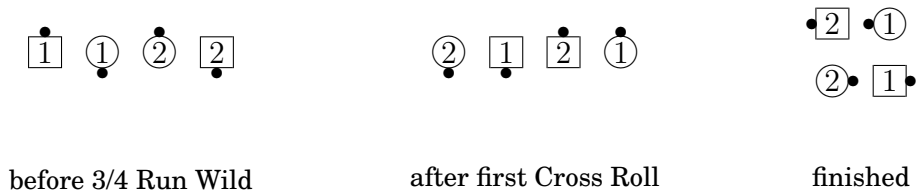

On a Grand Run Wild, do a Grand Cross Roll twice, re-evaluating after the first.

On a Grand Cross Roll, the center 6 Grand Cross Run (as in a Grand Mix) while the very ends Run.

Sashay Thru

Do-Sa-Do 3/4 and Slither.



Scamper

Typically from a 3/4 tag: the ends Divide and Touch 1/4, while the centers Hinge and Box Circulate. If the Centers are facing couples, they Touch 1/4 and Box Circulate.

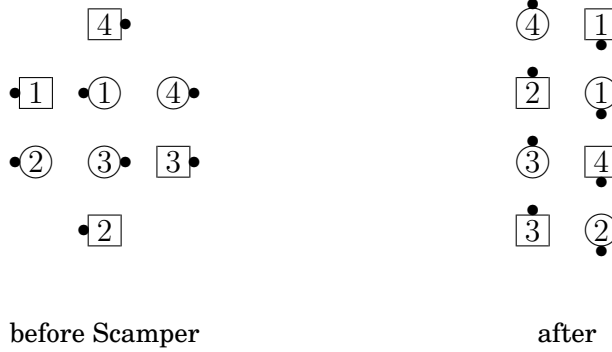

Scatter Follow to a Diamond, Scatter <anything>

On calls that have the leads doing (or starting with) a Scoot Back, the “Scatter” modifier has them do a Scatter Scoot instead. Examples are:

- Scatter Reach Out
- Scatter Follow to a Diamond
- Scatter Follow and Cross
- Scatter Scoot Chain Thru Reaction

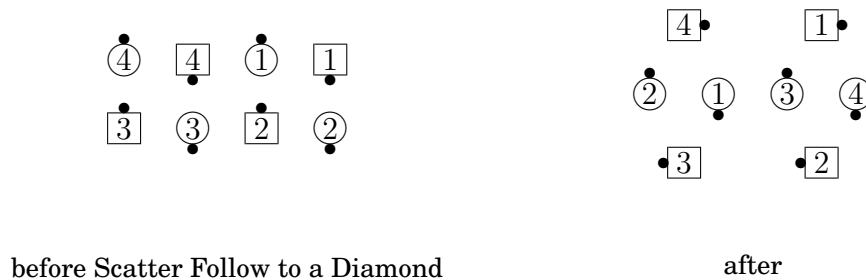

[Cross] [Criss Cross] Scoot Apart

This is somewhat like Reach Out.

From a box of 4: trailers step forward, Trade, and spread apart, while the leads Box Circulate 1-1/2

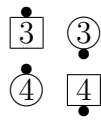

before Scoot Apart



after

On a Cross Scoot Apart, the trailers cross to opposite hands before the Trade.

On a Criss Cross Scoot Apart, the trailers cross to opposite hands, and the leaders also cross to opposite hands after the Box Circulate 1-1/2.

Scoot the Triangle

This is analogous to Scoot the Diamond. From a wave-based triangle, do a 1/4-tag type of Scoot Back (the base looking out just flips over to the other base position), the apex quarters to handhold, and all Triangle Circulate.

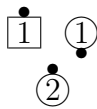

before Scoot the Triangle

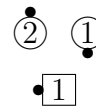

after

Set Back

All Trade, and then Lines Cross Back Thru.

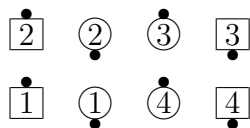

before Set Back

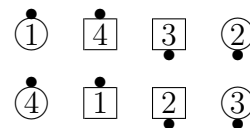

after

Because this sounds a lot like Settle Back (which seems to be a more common call), callers typically pronounce it very carefully. Dancers then help out by reciting the short definition.

Set Your Pace

From columns: Circulate 1-1/2, the center 6 Grand Follow Thru, then all Concentric Cycle and Wheel. Since this starts with a Circulate, it is subject to the “<anything> Set Your Pace” construction.

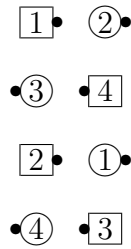

before Split Counter
Set Your Pace

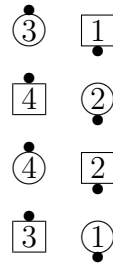

Split Counter Rotate

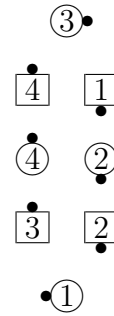

1/2 Circulate

③•

□4•

④•

•□1

□3•

•②

•□2

•①

①• ②• •□1 •□4

□2• □3• •④ •③

center 6 Grand Follow Thru

finished

Sets in Motion Plus 1 or 2

These are extensions of Sets in Motion in which additional people in the center column move out to the end. On a normal Sets in Motion, the first two people from the column become a couple—the first turns left and the second turns right. On Sets in Motion Plus 1, there must be a third person in the column. He turns left to stand between the other two in a line of 3. On Sets in Motion Plus 2, the third person turns left as before, and the fourth person turns right to stand between the second and third.

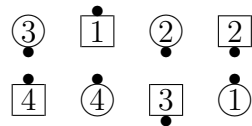

before Sets in Motion Plus 2

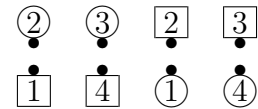

finished

Settle Back

This is a versatile call. Reset 1/2, Then the centers Cross Back while the ends do 2 O Circulates.

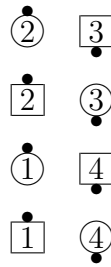

before Settle Back

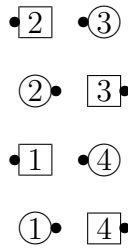

halfway

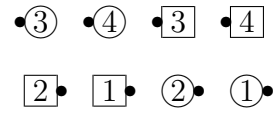

finished

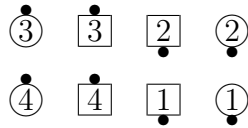

before Settle Back

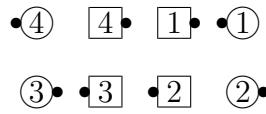

halfway

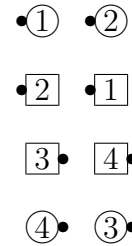

finished

This call has a confusing number of similarities with Set Back. Be careful.

This call has 2 parts. The first part, Reset 1/2, also has parts. This makes Settle Back a favorite for nested part-analyzing concepts.

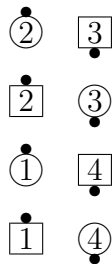

before
Initially Initially
Once Removed
Settle Back

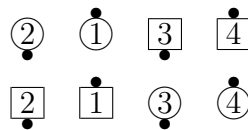

after Once Removed
Reset 1/4

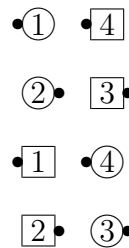

after Initially
Once Removed
Reset 1/2

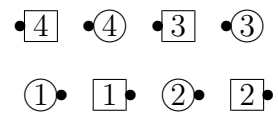

finished

Shadow Box <anything>, Shadow <formation> <anything>

From any setup in which the outsides are in tandem: the outsides do a 1/2 Zoom and Cast Off 3/4 while the centers do the <anything>. The outsides' part is the same as Cast a Shadow, but without the final Spread. The name of the center setup is used in the name of the call, as in "Shadow Wave", "Shadow Column", etc.

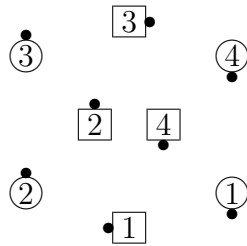

before Shadow Diamond Drop In

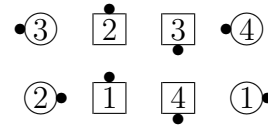

after

[Criss Cross] Shadow the Column

Cast a Shadow used to be considered legal from columns. It went from acceptable to controversial to illegal, and now lives on only under the name Shadow the Column. #1 and #3 do the 1/2 Zoom, Cast Off 3/4, and Spread. #2 does the Cloverleaf. #4 does the Extend (now Circulate 1-1/2), Hinge, and Extend.

On Criss Cross Shadow the Column, everyone's role is changed the way it is for Criss Cross the Shadow: #1 and #3 take opposite hands, and #4 crosses hands before the Hinge.

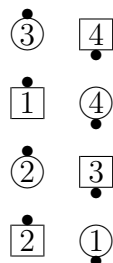

before Criss Cross Shadow the Column

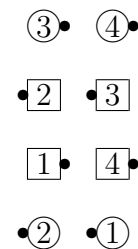

after

[Cross] [Criss Cross] Shadow to a Diamond

Ends Cast a Shadow. Centers effectively do a Peel and Trail with each other.

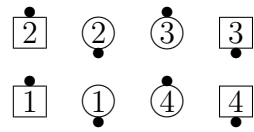

before Shadow to a Diamond

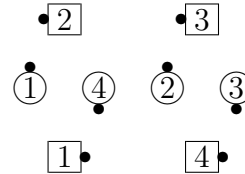

after

The centers' part also has a lot in common with Cast a Shadow. The center looking out avoids collisions the same way he would on a Cast a Shadow—he moves while the others are doing the Cast 3/4.

On Cross Shadow to a Diamond, the centers looking in extend to the opposite hand and Trade, rather like the action on Criss Cross the Shadow. The other 6 do the same thing as before.

On Criss Cross Shadow to a Diamond, in addition to the crossing action for the centers looking in, the ends Criss Cross the Shadow.

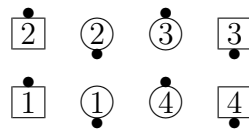

before Criss Cross Shadow to a Diamond

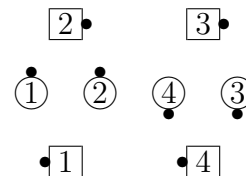

after

Ship Ahoy

From lines in which one end is facing out: the outer actives do a Recycle or Wheel and Deal as appropriate. The other center does a Shove Off inward, taking the adjacent end with her.

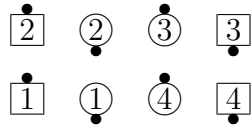

before Ship Ahoy

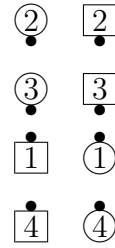

after

Short and Sweet

From any box of 4: leads do their part of Mini Chase while the trailers do their part of Short Cut.

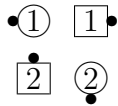

before Short and Sweet

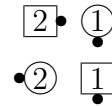

after

Short Cut

From facing couples: beaux (phantom) Touch 1/4 while the belles Partner Tag.



before Short Cut

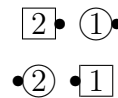

after

Short Cycle

From a line: centers U-Turn Back toward the nearest end and then Couples Hinge.

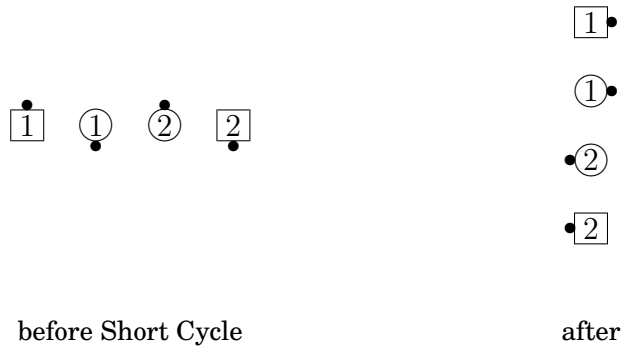

This call has a little bit of the “feel” of Recycle at Mainstream.

Short Trip

Usually from waves: the end looking out and the adjacent center Squeeze, while the others do their part of a Circulate.

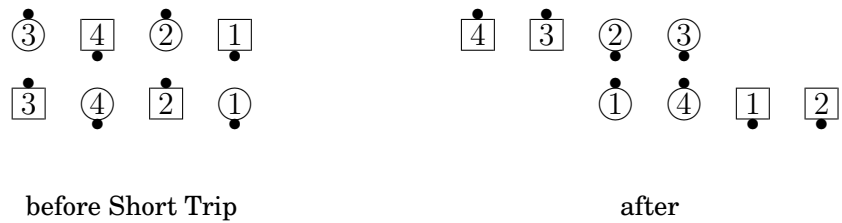

Figuring out who is to do which part, with the necessary speed, is quite difficult. If you are one of the squeezers, be prepared to help the other person.

Shove Off

From a 2-dancer formation consisting of the designated person and her lateral partner: the designee does a run or flip away from her partner, while the partner moves toward her without changing facing direction.

This is a “space invader” call. The motion is absolute.

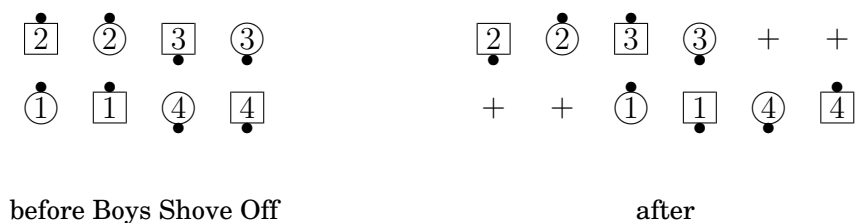

Shuffle and Wheel

This is like Shuffle the Deck, but the belle-side couple does a Wheel and Deal to face the beau-side couple.



before Shuffle and Wheel

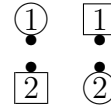

after

Shuffle the Deck

From a 1-faced line, the belle-side couple steps in front of the beau-side couple. This is an as-couples version of [Single Shuffle](#) (page 139), a call well known to people who are familiar with Vertical Tag.

Shuttle <direction>, Shuttle <anything>

From an 8 chain: all Pass Thru. The centers Slide Thru while the ends Quarter in the given direction, or take the given call. If no direction is given, they do nothing.

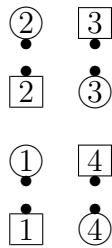

before Shuttle Left

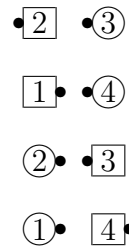

after

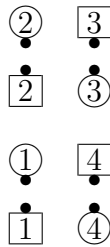

before Shuttle Sidetrack

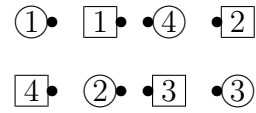

after

Siamese Breakdown

From any 2-person setup in which the two people are either adjacent laterally (couple or miniwave) or adjacent vertically (tandem, facing, or back-to-back): laterally adjacent people Single Wheel, while vertically adjacent people Single Turn to a Line.

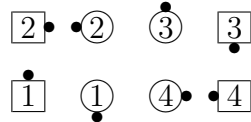

before Siamese Breakdown

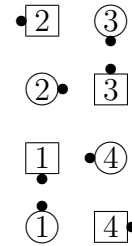

after

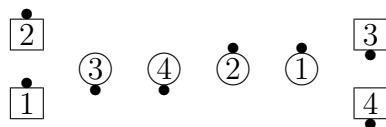

before Siamese Breakdown

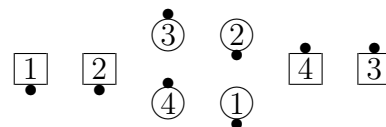

after

It is illegal to call this if the identification of pairs is ambiguous.

Single Hinge and Trade

Single Hinge and Trade is the start of the centers' part of Sets in Motion. All Hinge, centers Trade, all Roll.

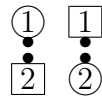

before Single Hinge and Trade



after

Hinge and Trade is the As Couples version of this. The Roll is also As Couples.

Single Hinge and Circulate <direction>

From a box: all hinge, then the centers trade while the ends Isolate (Counter Rotate), then all turn in the indicated direction.

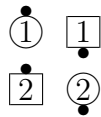

before Single Hinge and Circulate In

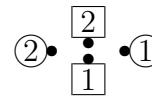

after

Hinge and Circulate is the As Couples version of this. The turn is also As Couples.

Single Scoot and Trade

From a 1/4 tag: Scoot back, then the ends Quarter to Handhold while the centers Hinge, making a 2-faced line. Finally, Lockit.

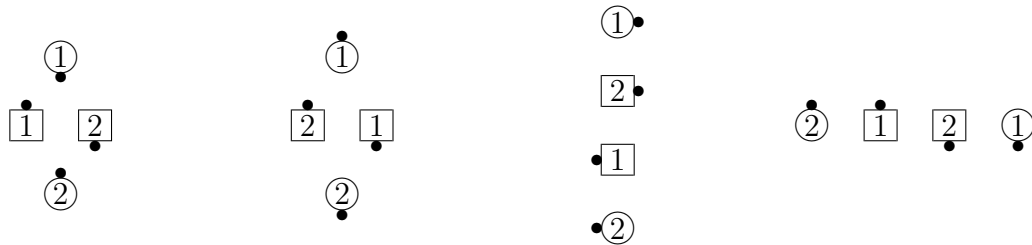

before Single
Scoot and Trade

After Scoot Back

Hinge, Quarter

finished

One might think that the As Couples version of this would be known as Scoot and Trade, but this appears not to be the case.

Single Shuffle

From a couple: The belle steps in front, creating a tandem. This is the start of Vertical Tag, for a couple facing in. It is also the start of calls like Dixie Style to a Wave, Dixie Chain, etc.

[Shuffle the Deck](#) (page 136) is the As Couples version of this.

Slim Down

This takes any 2x4 into a 2x4 oriented the other way. Centers become ends and ends become centers, all by moving forward, back, or sideways, without turning.

The ends simply move into the center. The centers move out along the opposite axis. If your nearby end is coming in from your left or right, move forward or back, or vice-versa.

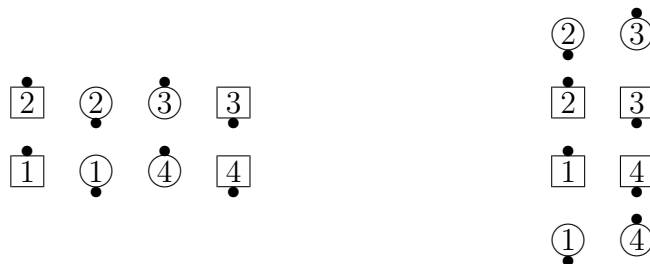

before Slim Down

after

From back-to-back lines, this is the same as Step and Slide.

Slim down can be done in other formations, as long as each quadrant has one center and one end that are as if in a 2x4.

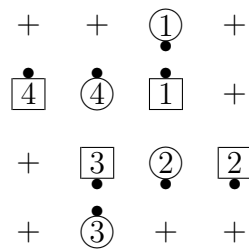

before Slim Down

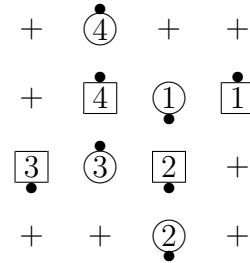

after

Snag Circulate

Ends do an All 8 Circulate, while the centers do 1/2 of a Circulate. This is a special case of the “Snag” concept (centers work 1/2), which is a special case of the “Snag the <anyone>” concept (designees work 1/2).

Snake

From a miniwave: Quarter In and step to a new miniwave of opposite handedness.



before Snake



after

Snap

Partner Tag. See Snap, Crackle, and Pop.

Snap, Crackle, and Pop

This combination was inspired by a promotional slogan for a breakfast cereal.

See those 3 calls. They are sometimes put together in other orders or other combinations for comic effect.

Snap Back

This is a “Fast Snap the Tag Back”—Snap the Tag 1/4 only, centers Trade, Extend.

Snap the Diamond

From parallel diamonds: All do a Diamond Partner Tag. (Use the “Diamond” concept; work to spots; try to avoid injury.) Then the outsides Partner Tag again, while the centers Right Roll to a Wave.

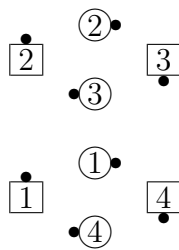

before Snap the Diamond

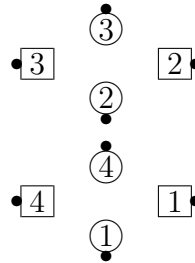

after first Tag

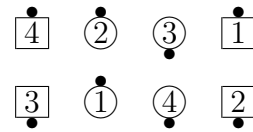

finished

Snap the Tag <N/4>

This is a tagger. First, all Partner Tag. Then the ends U-Turn Back, and then all Extend as many times as needed. The tagging is always right shoulder. From a right-handed wave this is the same as Flip the Line.

When the “Reflect” modifier is used, an ambiguity arises, because this is a tagger with another tag inside it. The caller may want the “Reflect” to apply to the initial Partner Tag, that is, Partner 1/2 Tag, Arm Turn 1/4, and Step Thru.

Due to ambiguity with the call “Snap”, the caller must always say “Snap the Tag”. It is improper to say “Snap Your Neighbor”. Also, “Snap Back” is a different call.

Sock it to the Diamond, Sock it to the Wave

See [In Roll To a Diamond](#), page 85, or [In Roll To a Wave](#), page 86.

Soft Touch, Soft <anything>

From a line or diamond: centers Hinge and flip away. The others Quarter In, step ahead, and Touch.

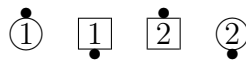

before Soft Touch



after

For Soft <anything>, the <anything> replaces the Touch.

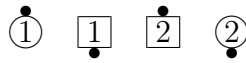

before Soft Touch 1/4

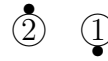

after

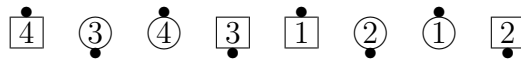

before Soft Pass and Roll

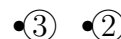

after

Spin a Wheel

Couples Hinge; Triple Trade; Couples Hinge. The three parts of this call are frequently exploited with interrupts or part-analyzing meta-concepts.

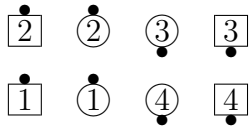

before Finally Cross Concentric
Spin a Wheel

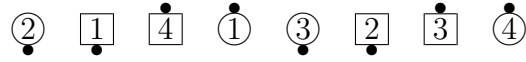

after

Spin Back, Fan Back

On a Spin Back, all Trade (or Touch 1/2). Then the centers cast 3/4 while the ends U-Turn Back.

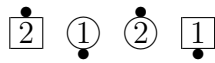

before Spin Back

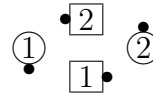

after

Fan Back omits the first Trade, of course.

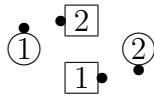

before Fan Back

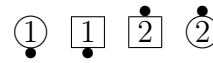

after

These are normally 4-person calls, so that, when done from a tidal wave, “centers” means the centers of each side. But beware—when necessary, they might not really be 4-person calls.

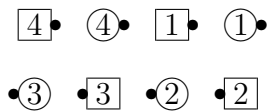

before Fan Back

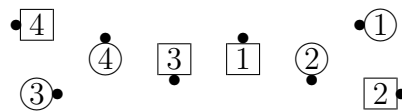

after

Spin Chain and Anything

See <anything> and Anything, page 21.

Spin Chain and Circulate In, Fan Chain and Circulate In

On Spin Chain and Circulate In, all Trade (or Touch 1/2). Then Fan Chain and Circulate In, which is the same as 3/4 Chain and Circulate In: Ends Circulate and then Cross Over Circulate, while the centers Cast 3/4, center 2 Trade, Cast 3/4, and Spread.

Fan Chain and Circulate In omits the first Trade, of course.

Spin Chain and Circulate the Gears, Fan Chain and Circulate the Gears

This is similar to Spin Chain the Gears, but in each of the instances in which the ends turn around, they follow it with a Circulate.

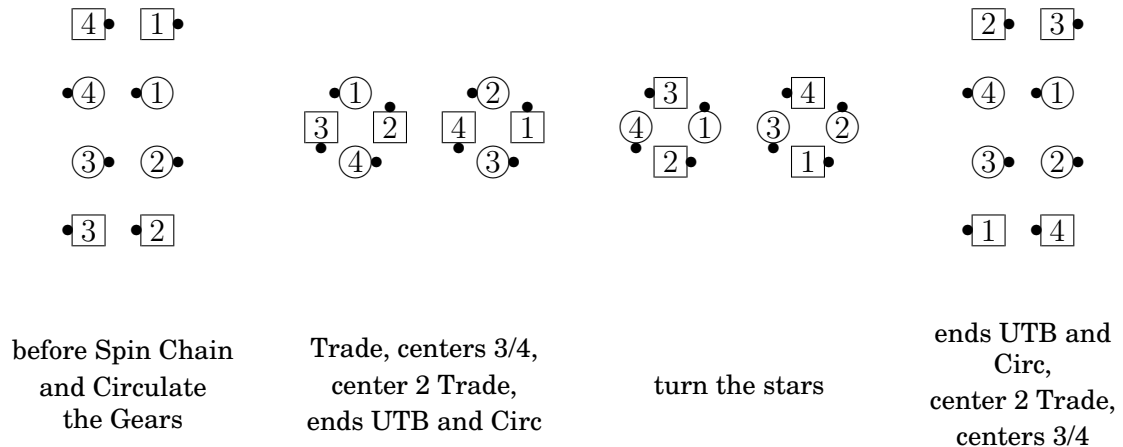

Fan Chain and Circulate the Gears omits the first Trade, of course.

Spin Chain the Star

This is a 2-3-2-3 Quarter the Deucey, if that's helpful. All Trade. Centers Cast 3/4. The end looking out Circulates, while the end looking in steps forward into a star. The center star turns 1/2. This is sort of like the center 2 trading on Spin Chain Thru, but there are two other people "riding the star". Then those who meet Cast 3/4 while those who rode the star move forward to the end of the line.

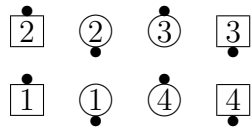

before Spin Chain the Star

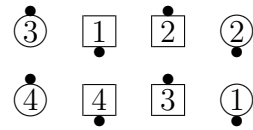

after

Spin Tag the Deucey [<direction>]

From waves: Centers and adjacent ends Trade. Centers Cast 3/4. Center 2 Trade while the ends tag with each other through the gap that is created. After tagging, the ends 1/4 in the indicated direction and Circulate one position, while the centers Cast 3/4. If no explicit direction is given, the default is right.

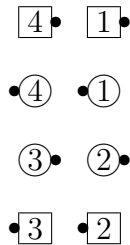

before Spin Tag
the Deucey

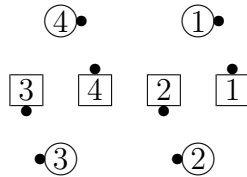

Trade, centers Cast 3

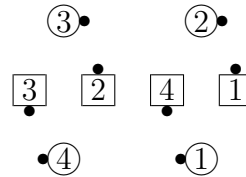

center 2 Trade,
ends Tag and Face Right

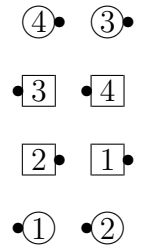

finished

Spin the Yoyo

This is an old name for what is now called Yoyo Spin the Top.

Splash <direction>, Splash <anything>

From lines: Outer actives (end looking out and adjacent center), whether they are a miniwave or a couple, Explode the wave or line. Inner actives Vertical Tag and take the direction or call.

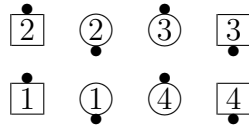

before Splash Out

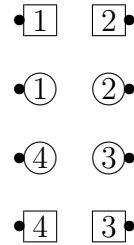

after

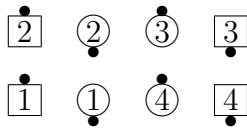

before Splash [Single Shake and Rattle]

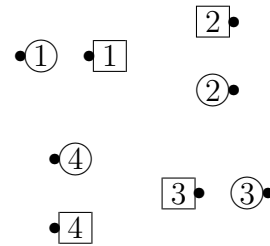

after

Split and Cross

Split Circulate and Cross.

Split Cast, Split Cast <N/4>

Usually from a “Heads Touch” setup: centers Cast Off 1/2, while the ends Hinge and then Trade. The centers’ Cast Off might be pushy. The ends’ action is not.

If a fraction is given, everyone casts by that amount after the initial ends Hinge. Hence Split Cast is equivalent to Split Cast 1/2.

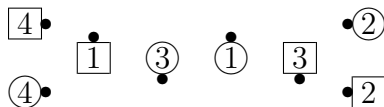

before Split Cast

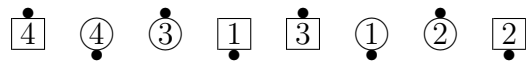

after

Split Ping-Pong Circulate

This is the 4-person version of Ping-Pong Circulate. The people going to the outside just U-Turn Back.

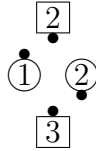

before split ping-pong circulate

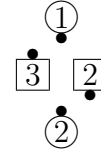

after

Split the Difference

Split Circulate, the Difference. This has 4 parts.

Square Out

From an 8 chain: centers Square Thru 4 while the ends 8 Chain 2 and Square Thru 2.

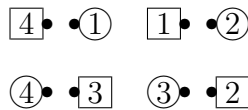

before Square Out

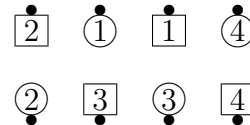

after

It may be helpful to think “Second hand grand.”

Square the Barge, Square the Barge <N/4>

Square Thru 4; Trade By. If a number is given, it dictates the number of hands in the Square Thru.

See [Barge Thru](#), page 25.

Square the Barge the Action, Square the Barge <N/4> the Action

This is a combination of “Square the Barge” and “The Action”— Square Thru 4; The Action.

If a number is given, it dictates the number of hands in the Square Thru.

See [Barge The Action](#), page 24.

Square The Bases Plus 2

This is a Square the Bases, but the Split Square Thru 2 is changed to a Split Square Thru 4.

Square Turn Thru <N>

Square Thru, but on the last hand do a Natural Turn Thru instead of a Natural Pull By.

Stack the Wheel

As couples Hinge, individually Roll.

Star to a Wave

From facing couples: Make a right-handed diamond by having the beaux step forward to each other, while the belles 1/2 flip left. (This could be precisely defined as 1/2 Reverse Swap Around.) Counter Rotate the diamond 1/2, or whatever “star turn” amount is indicated. Flip the Diamond.



before Star to a Wave

after

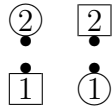

before Star to a Wave,
Turn the Star 3/4

after

This call is very similar to Tag the Star. It is Tag the Star 1/2 followed by Hinge.

Step and <anything>

This is a generalization of Step and Slide. The centers step ahead, and the others do whatever the call is, as in Step and Flip or Step and Squeeze.

Step Lively

Detour, Slim Down, and Circulate. This has 3 parts.

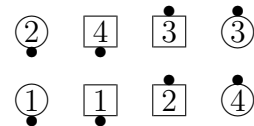
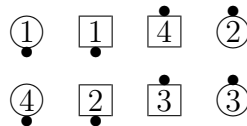
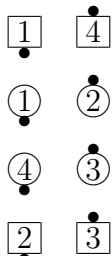
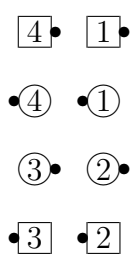

before Step Lively

Detour

Slim Down

Circulate

The original definition of this call was quite different, and in fact long predated Slim Down. The recognition that it was equivalent to the 3-call series given above, and the adoption of that as its definition, was more recent. The original definition only worked from waves, and was not fraction-izable. Purists may consider the reformulation improper. It is nevertheless widely accepted.

[Cross] Straight Away [but <anything>]

From a 1/4 tag or 1/4 line: the end of the center line Extends to the nearest outside and does a Release Recycle with that person. The very center flips out. The outside person not participating in the Recycle presses ahead to the very center.

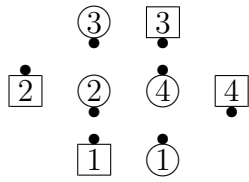

before Straight Away

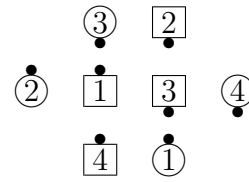

after

If the “Cross” modifier is given, the person doing the press ahead instead Jay Walks to the opposite center spot.

If a modifier call is given, it replaces the Recycle. Phantoms are still removed to the extent possible.

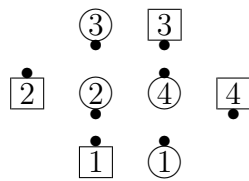

before Cross Straight Away
but [Ah So]

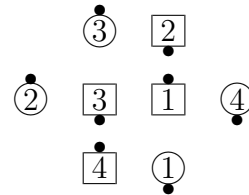

after

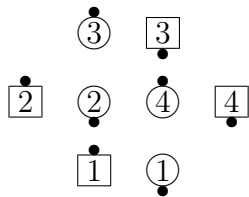

before Straight Away
but [1/2 Tag]

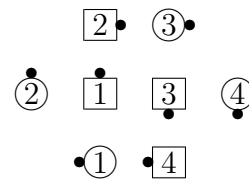

after

Straight Fire

From 2-faced lines: ends looking in Cross Over Circulate, while the others Crossfire.

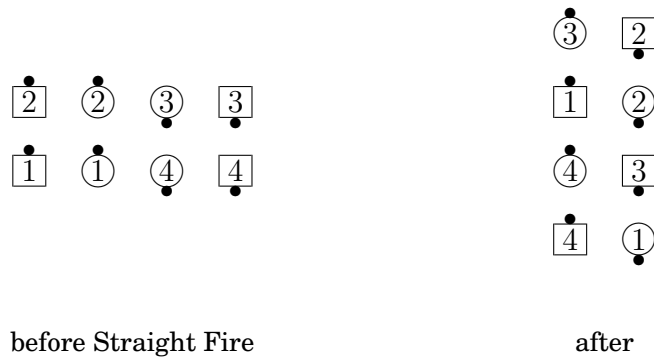

This is the call that gave rise to the “Straight” concept. It is simply a Straight Crossfire. Another common member of the family is “Straight Connect” which is Straight Connect the Diamond.

Strike Out

Centers Hinge, then all Collapse.



Stroll and Cycle, Stroll <anything>

From a 1/4 line: center 2 trade, while the end of the center line Extends to the nearest outside and does a Release Recycle with that person. They then Veer or do a “Plus 2” to become a trailing couple in lines. The other outside people step forward beside the center 2 who have traded, and they step ahead to become a lead couple in lines.

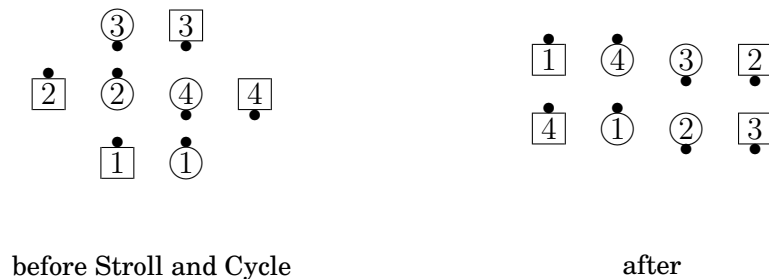

If a modifier call is given, it replaces the Recycle. Phantoms are still removed to the extent possible, and those people still move into the appropriate quadrant.

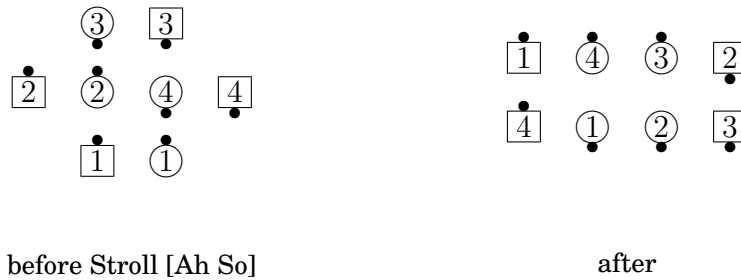

Stroll Down the Lane

From facing lines: The end on the left presses out to meet the other end, then they Recycle and Veer Left. The centers Hammerlane and step forward.

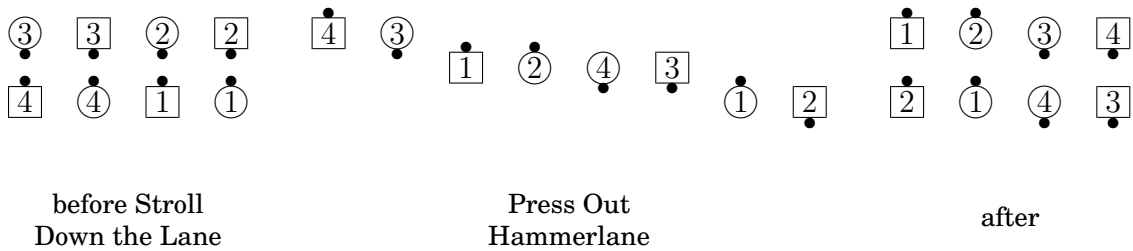

[Reverse] [Cross] Swap the Windmill

Carefully do 1/2 of a Swap Around or Reverse Swap Around. If the “Cross” modifier has been given, those who come in to the center take opposite hands. The setup should now be two stars of some kind. Adjust those stars if necessary so that there is a wave down the middle. In the wave, Swing, Slip, and Cast Off 3/4. The others, while staying out of the way of the people in the wave, Circulate twice around the outside.

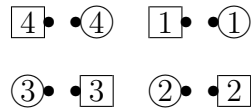

before Reverse Cross
Swap the Windmill

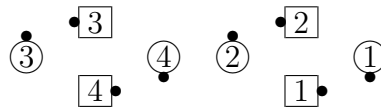

1/2 Reverse Swap around
with crossed hands

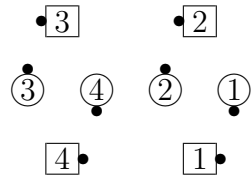

adjust stars

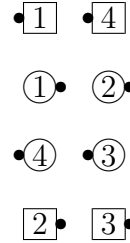

finished

It may help to be aware that the call starts a lot like Swap the Top, with the “Reverse” and “Cross” modifiers having the same meaning.

Substitute

This is an orphaned call from lower levels. It is just a Dive Thru, independent of facing directions, and without the Trade on the outside. The centers make an arch and move to the outside, while the ends duck under the arch and move to the center. The starting setup is typically a DPT, so the centers back out over the ends.

Swat the Flea

Mirror Box the Gnat. The girl still goes under.

Sweeping <anything>

Sweep 1/4, and then **finish** the <anything> call. See [Rolling <anything>](#), page 120.

Swing About

Swing, Slip, About.

<anyone> *Swing Across*

This is sort of an <anyone> Ripple the Line, except that the designees switch over to the other line in the middle of the call. Designees, who must be ends, Trade with adjacent center, then Trade with each other on the diagonal in the center, then Trade with new adjacent end.

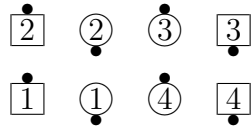

before Head Boys Swing Across

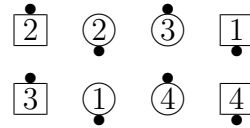

after

Swing and Cross

This is perhaps the most obnoxiously misnamed call ever. It predates the now-common use of <anything> and Cross.

Cast Off 3/4 and Cross.

Swing Back

Swing, Slip, Slip.

Swing Chain Thru, etc.

A call that starts with the phrase “Swing Chain” is like the equivalent “Spin Chain” call, except that all 3/4 Casts and Star Turns are changed to 1/4. Trades and Star Turns of 1/2 are not affected.

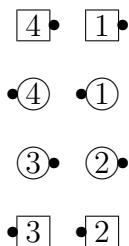

before Swing Chain Thru

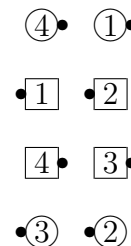

after

Other examples are Swing Chain the Line, Swing Chain the Star, Swing Chain the Gears, Swing Chain and Circulate the Gears, and Swing Chain and Circulate In.

Swing to a Column

From a generalized 1/4 tag (usually a right-handed 3/4 tag): centers Trade and Roll and then walk forward, passing right shoulders, to become #1 and #2 of a column. Ends Divide, Touch, and do a sort of Flip the Line 1/2 to become #3 and #4 of that column. All passes are right shoulder, even if the starting formation makes that awkward.

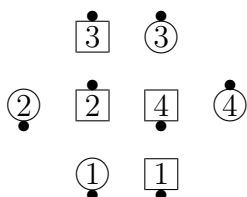

before Swing to a Column

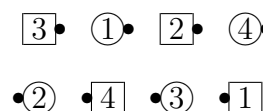

after

Switch Back

Switch to a Diamond, the centers Trade, and Drop In.

Switcheroo

Switch to a Diamond, Eroo. That is, the centers Cast Off 3/4 while the ends Circulate.

<anyone> [Cross] Swivel

From a couple: The designated person Fold. The two people then left or right Single Circle to a Wave, in the direction dictated by the flow from the Fold.



before Belles Swivel



after

On a Cross Swivel, start with a Cross Fold.

Tag Circulate

Trailers Circulate. Leads Tag the Line and face right. It's always right.



Because this is a Circulate variant, it can be used in the “anything anything” construction, as in Tag Percolate. This can lead to confusion. Phrases like “Tag Percolate” sound more like tagging variants than Circulate variants, so dancers often start doing the wrong thing before figuring out what is really wanted.

Tag the Star <N/4>

This is a tagger.

From facing couples: Make a right-handed diamond by having the beaux step forward to each other, while the belles 1/2 flip left. (This could be precisely defined as 1/2 Reverse Swap Around.) Counter Rotate the diamond 1/2, or whatever “star turn” amount is indicated. Drop In gives the 1/2 tag position. Proceed (or back up) as required.

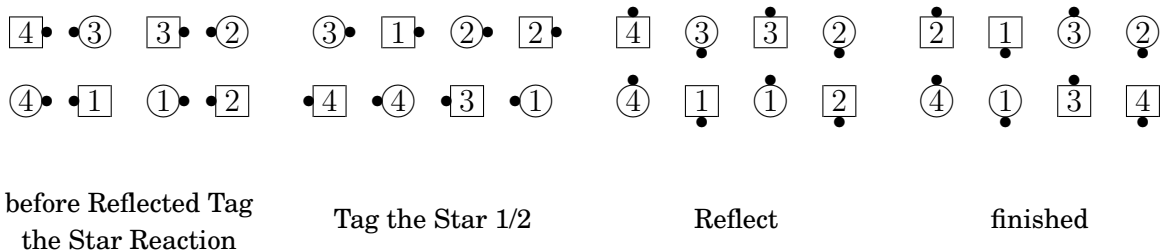

Tap the <anyone>

From facing couples: all Pass Thru, designated people U-Turn Back, all Box Counter Rotate, and Roll. This has 4 parts. If it makes a difference, people re-evaluate whether they are designated just before the U-Turn Back. (Of course, the caller could say something like “Tap the original centers”.)

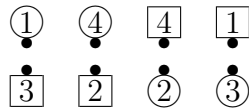

before Thirdly Once Removed
Tap the Girls

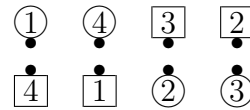

after

Teacup Like a Daisy Chain

Pictures and words cannot do justice to this call. It is like a Teacup Chain, except that the girls (belles, actually) go forward 2, back 1, forward 2, back 1, and forward 2 to their partner. When going forward, the usual rules apply—into the center for an appropriate Arm Turn whenever they are at the heads position (assuming it was Head Ladies Center for a Teacup Like a Daisy Chain), and directly to the next boy if at the sides position. When going backward, they do whichever they did (Arm Turn in the center or direct) on the forward motion that got them there.

When reversing direction (either forward to backward or backward to forward) on a direct motion, turn an extra full turn with that boy, to make the timing more uniform relative to the other girls who have to go into the center.

The girls strictly alternate hands at all times. If done correctly, it should end with the left hand free for a Courtesy Turn with original partner.

As usual, the boys make hands available as required, and otherwise try not to be actively helpful.

There is a trick that some people find helpful to keep track of the forward and backward motion, particularly those that like baseball analogies. Imagine that you have hit a home run, and have to go around the baseball diamond, touching each base. You must traverse the base line between 1st base and 2nd base three times: forward to second, back to first, and forward to second again. Similarly, you must traverse the base line between 2nd base and 3rd base three times. The motion from home plate to first base, and from third base back to home is normal. Remembering where you are on the baseball diamond may make it easier to keep track of the extra motion.

So, for example, the head girls go in to the center with a right hand and then to their corner with a left hand, go directly to their opposite boy with a right hand, turning once and a half with him, back to original corner with a left hand, turning once and a half with him, forward to opposite with a right hand, in to the center with a left hand and then to their left-hand gentleman with a right hand, back in to the center with a left hand and then to their opposite boy with a right hand, in to the center with a left hand and then to their left-hand gentleman with a right hand, and directly home for a Courtesy Turn.

The Action

This is sort of the last half of Chain Reaction.

Typically from a Trade by: ends Hinge and then Trade, while the centers make a right-hand star by doing a 1/2 Reverse Swap Around, and turn the star 1/4. Then finish like a Chain Reaction—center line Cast off 3/4 while the others “move up”.

The ends’ part is exactly the same as Linear Action.

The centers’ part starts like Star to a Wave or Tag the Star, except that the star turns only 1/4, and it isn’t important who the points and centers are.

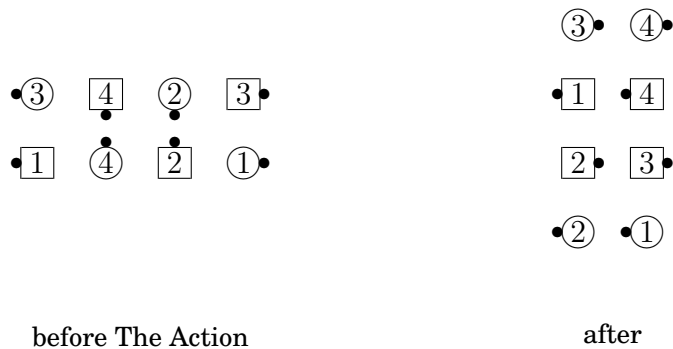
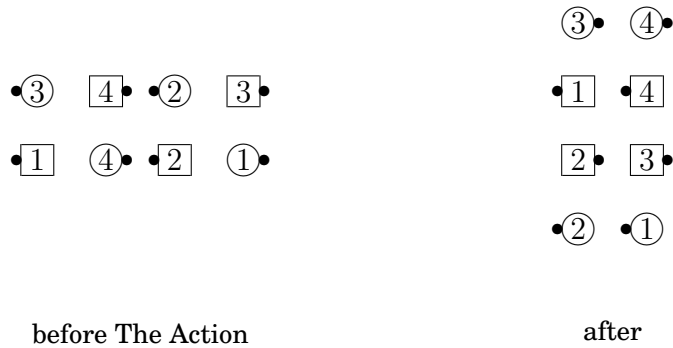

The Difference, Split the Difference, <anything> the Difference

The Difference is Cast Off 3/4, Slip, Cast Off 3/4. This has 3 parts. It is often used as a suffix, as in Mix The Difference. Such things have 4 parts. Fractionalization is very commonly used.

Split The Difference is Split Circulate The Difference. Split Trade The Difference is Split Trade Circulate The Difference.

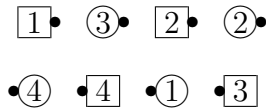

before Random Once Removed
Split the Difference

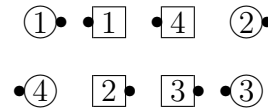

after

The Plank

See [Walk the Plank](#), page 174.

Tickle

Hinge, then Split Counter Rotate.

From waves, this is the same as Ah So, but don't get too dependent on that fact.

[Cross] <anyone> Tie

Often from a completed DPT: all Peel Off. Then the original designees Couples Circulate and Bend the Line, while the others Bend the Line and Couples Circulate.

This is typically Beau Tie or Belle Tie, though any designator can be used, as long as the Bend the Line and Circulate decisions are consistent in each couple.

This is a hard call! You must take note of whether you will be designated for the Circulate and Bend before doing the Peel Off, since beaus and belles will change.

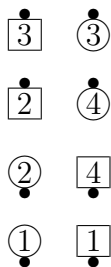

before Beau Tie

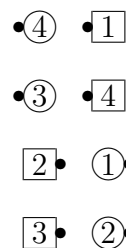

after

On a Cross <anyone> Tie, start with a Trail Off.

Tip Toe, Tip Toe Thru the Tulips

On a Tip Toe, the designated people Press ahead, dragging their partner (often backwards) with them. On Tip Toe Thru the Tulips, after the Tip Toe, the non-designated person Runs.

Touch and Go $\langle M/4 \rangle \times \langle N/4 \rangle$, Touch and Go $\langle M/4 \rangle \times \langle \text{anything} \rangle$, etc.

From columns: all $1/2$ Circulate. The outer 2 Isolate and Circulate, while the other 6 Cast the first fraction. (That fraction must be odd.) The 4 who meet Cast the second fraction while the other 2 Isolate.

Stimulate the Column is Circulate and then Touch and Go $1/4 \times 3/4$.

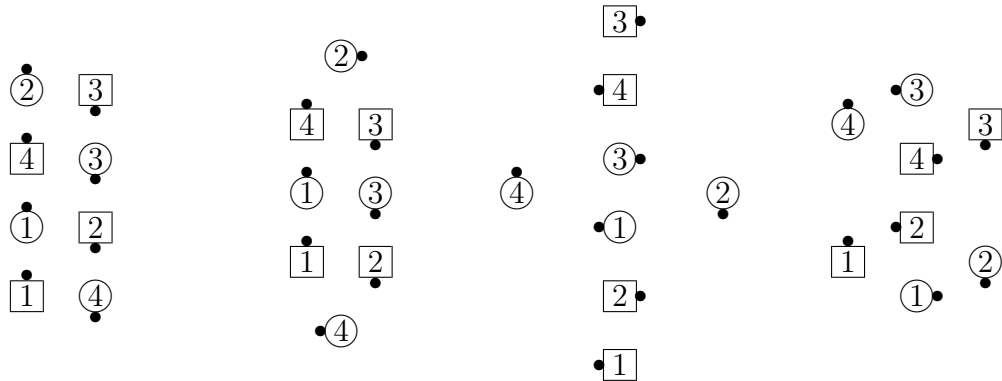

before Touch and Go
 $3/4 \times 1/2$

half Circulate

first fraction

finished

The fractions might be replaced with calls, as in Touch and Go Shazam $\times 2/3$ Recycle.

Touch of Class

This is called either “Touch of Class” or “With a Touch of Class”.

From waves: leads Switch (rather like another call that ends in “class”) and Circulate. Trailers extend, Recycle, Plus 2.

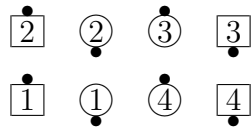

before Touch of Class

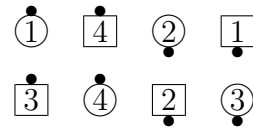

after

Touch Tone <M/4> x <N/4>

From waves: trailers Extend and Cast the first fraction with each other. Leads Extend, Cast Back, meet each other with the same hand they had in the original wave, and Cast the second fraction.

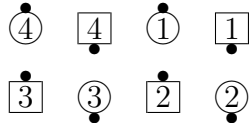

before Touch Tone 1/4 x 1/2

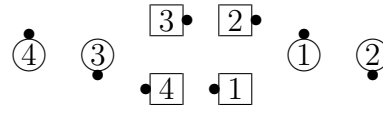

after

A call may be used in place of a fraction.

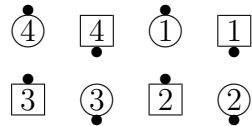

before Touch Tone 1/2 x Shazam

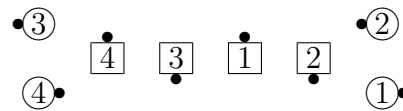

after

Tow Truck

The designated person does a Truck, dragging her partner along. The caller may designate a number of people to drag.

Track <N>

This is the obvious consequence of thinking of "Track" as a tagger. Tandem Trade and then Extend as necessary to the <N/4> tag position.

Track and Trade, Track and <anything>

Typically from columns: the first two people Track 2, while the others move in and do the given call.

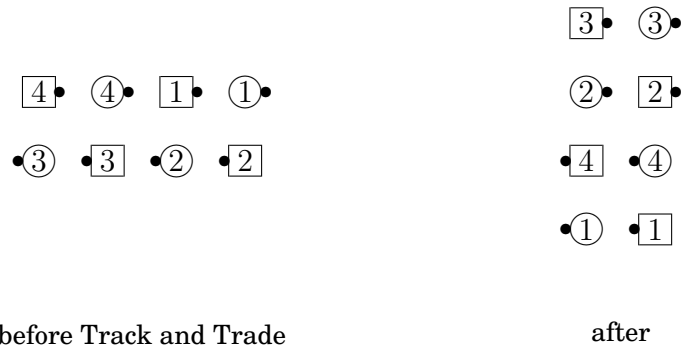

[Cross] Trade Your Neighbor [<direction>]

From waves: trailers Follow Your Neighbor (or Cross Your Neighbor). The leads step ahead, Quarter in the indicated direction, and Circulate one position.

If no direction is given, the default is right.

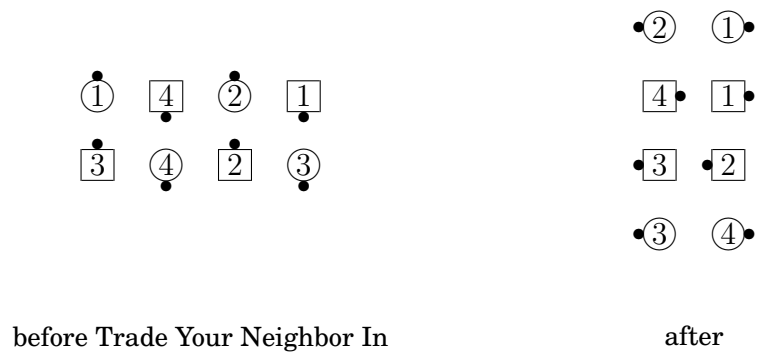

Trail and Peel

This forms the logical completion of the Peel Off / Trail Off / Peel and Trail family. Leads Trail Off, while the trailers Peel Off.

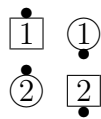

before Trail and Peel

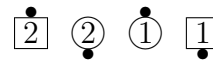

finished

Trail Chain Thru

This is just a Peel Chain Thru, but the outsides do a Cross Cast Back instead of a Cast Back.

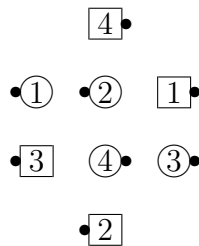

before Trail Chain Thru

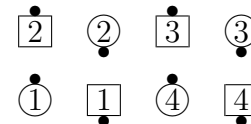

after

The timing is rather awkward, so the original center 2 need to wait before doing the Fan the Top.

Trail The Top, Trail <anything>

This is like a Peel the Top, but the leads Trail Off and Isolate instead of Peel Off and Isolate.

Like Peel the Top, this can be done from Z's.

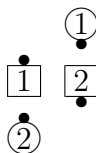

before Trail the Top

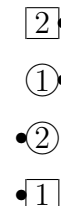

finished

If one hears “Trail” in other contexts, it means replace a Peel Off action with a Trail Off action, as in Trail Chain Thru or Trail the Bobbin (another name for Cross Wind the Bobbin.)

Transaction, Transactivate, Trans <anything>

On a Trans <anything>, Transfer and centers Cast Off 3/4, followed by <anything>.

It is common for the <anything> to involve all 8 people, as in Trans Nuclear Reaction.

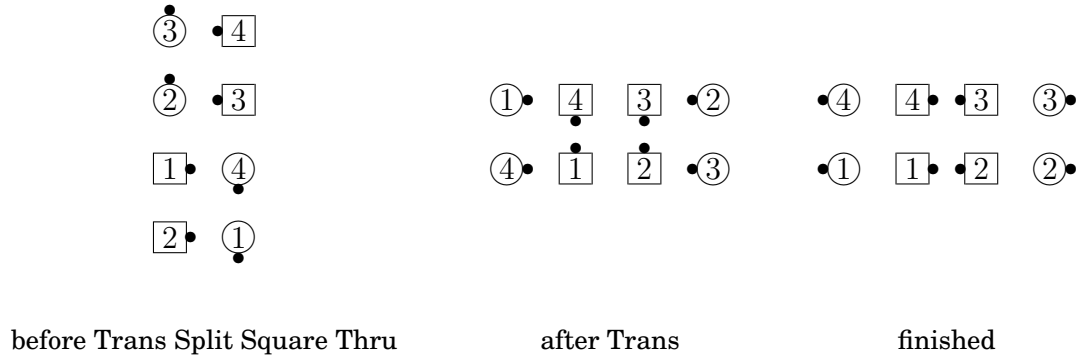

Trans Chain Reaction is called Transaction. Trans Reactivate is called Transactivate.

Trim the Web

From an “I” or “Heads Move In” type of setup: centers Trade (or Touch 1/2). The very centers are now finished. The other centers form a 3-person star with the outsides, helping the outsides decide which hand to put in to make the star consistent. That star turns 2/3. After the star turns, the two people on the outside of the star adjust to be a couple facing in.

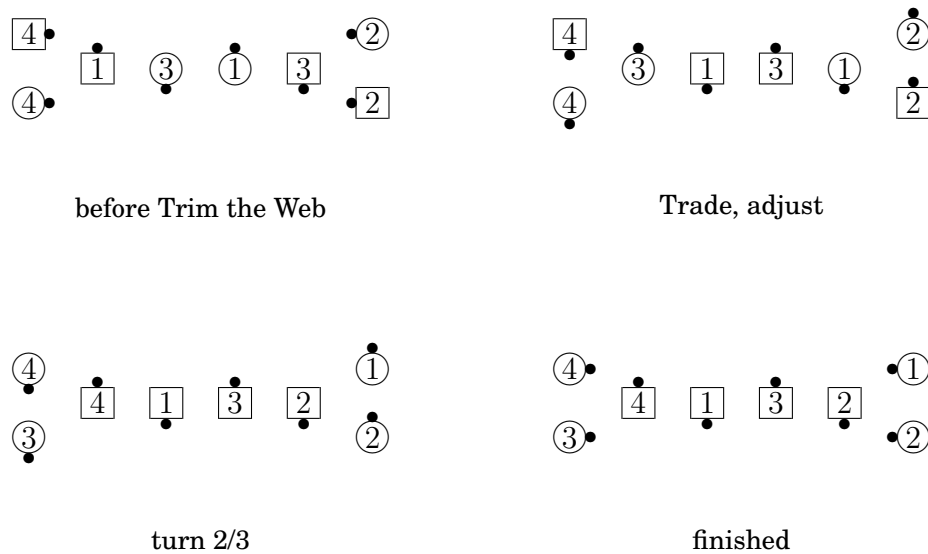

Triple Cast

Typically from a tidal wave: center 6 Cast Off 3/4, while the outer 2 U-Turn Back away from the center, and Isolate. The center 2 then “move up”.

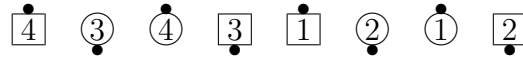

before Triple Cast

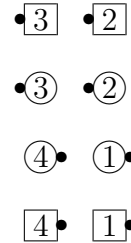

after



before Triple Cast

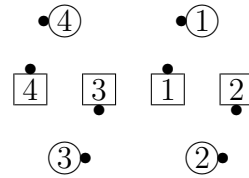

after

Triple Play <anything>

This is analogous to Trans <anything> or Open Ups <anything>. Do a Triple Play without the final extend. (The centers still do the final Hinge.) Then do the <anything> call. This is commonly used in things like Triple Play Reaction or Triple Play Nuclear Reaction.

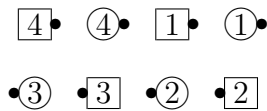

before Triple Play Reaction

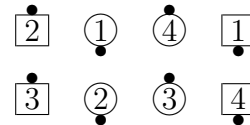

after

Triple Turn, Triple Wheel

Triple Turn is Turn to a Line, Turn and Deal, and Turn to a Line.

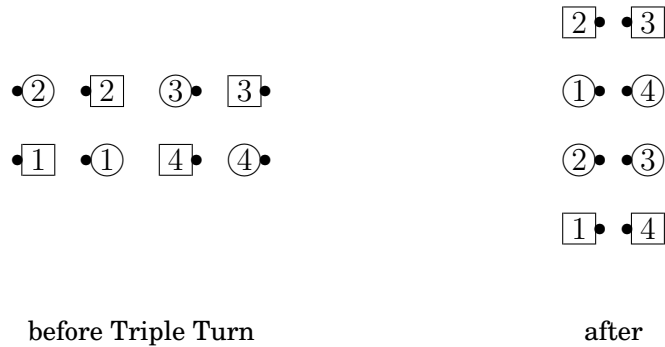

Hint: After the first two parts, everyone should be switched with the person in front or back.

Triple Wheel is Wheel to a Line, Wheel and Deal, and Wheel to a Line. The hint given above might not apply to this call in all cases.

These calls have 3 parts.

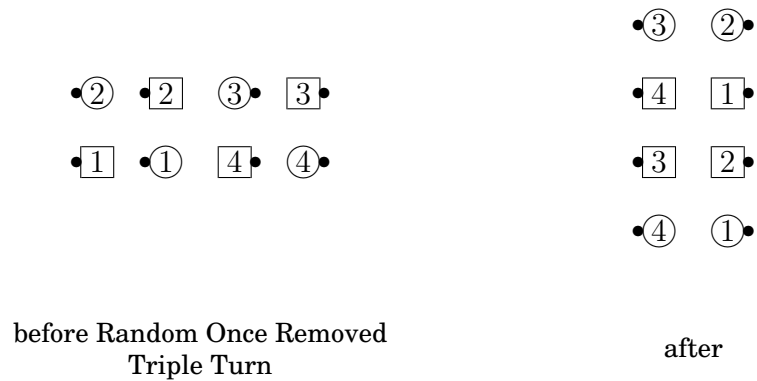

Trixie, Trixie Spin

Trixie is done from a box of 4: leads Quarter In and Trailers Quarter Out.



This is surprisingly hard, but there is a useful trick. Just as Zig Zag is often described as “throw your right hand in” (that is, turn 1/4 so that your right hand is toward your “tandem partner”), Trixie can be described as “throw your inside hand in”. Whichever hand you have joined with your lateral partner, turn 1/4 to join that hand with your original tandem partner, who becomes your new lateral partner.

Trixie Spin has 3 parts: Trixie, Cast Off 3/4, and Centers Cross Run.

Tunnel <direction>, Tunnel <anything>, Tunnel Thru

From general columns: centers Partner Tag, step ahead, and Trade with each other. Ends Vertical 1/2 Tag into the center, and Quarter in the specified direction. The directions “in” and “out” are relative to the center.

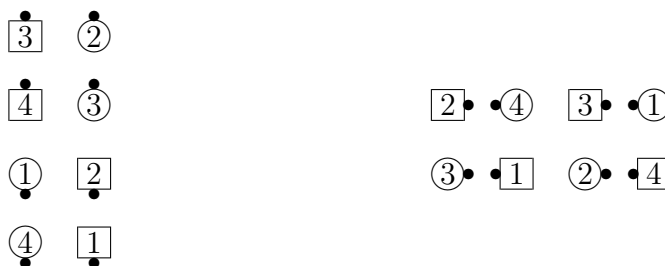

before Tunnel Out

after

On Tunnel <anything>, the original ends do the <anything> after their Vertical 1/2 Tag into the center

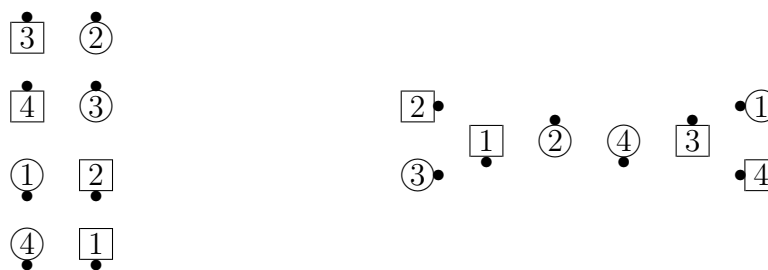

before Tunnel Reach Out

after

On Tunnel Thru, the Vertical Tag is all the way through, and may be followed by a direction in the usual way.

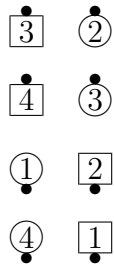

before Tunnel Thru Zig-Zag

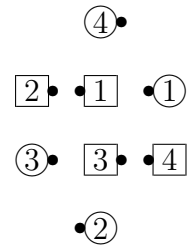

after

Turn and Flip

From facing couples, the beaux Scoot Back, while the belles (as on Reverse Swap Around) flip to their left.

Turn and Left Thru

This is an old Quarterly Selection. Turn Thru and Courtesy Turn.

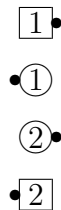

before Turn and Left Thru

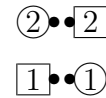

after

Turn and Q, Split Turn and Q

From facing couples: Turn Thru, Quarter In, and Left Turn Thru.

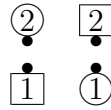

before Turn and Q

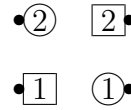

after

On a Split Turn and Q, those facing Turn Thru, then face the others and Left Turn Thru.

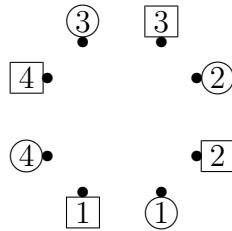

before Heads Split Turn and Q

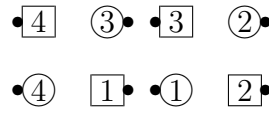

after

Turn and Weave

This is a 4-person call. The “Turn” is a Trade or Touch 1/2. The rules for this, and the rules for the Weave, are complex.

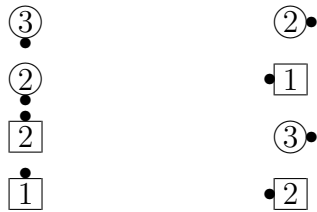

before Turn
and Weave

after



before Turn
and Weave

after

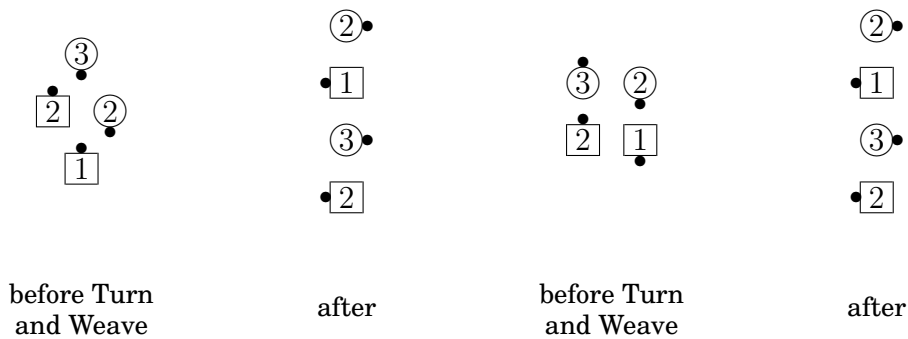

I recommend thinking of this in terms of 4 actions—“Touch, Trade, Extend, and Weave”.

Touch if necessary until at least some people are in a miniwave.

Those in the miniwave(s) trade.

Extend if necessary until *everyone* is in miniwaves.

Weave.

Turn Away

Typically from a completed DPT: belles Peel Off and Circulate. Beaus Trail Off.

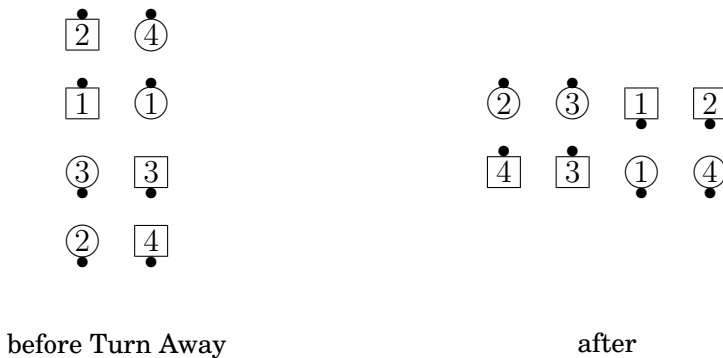

From other setups, follow the definition.

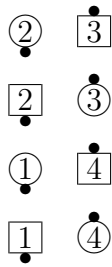

before Turn Away

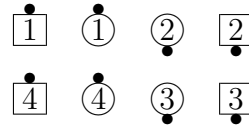

after

Turn By

This is basically a Single Trade By. The outsides always turn to the right.

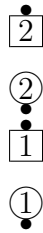

before Turn By

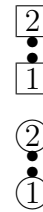

after

Well, not really. It's actually a Single Eight Chain or Single Trade By, as needed. This allows for such things as this extremely common usage:

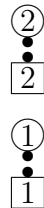

before Turn By 1-1/2

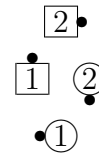

after

Turn On

Split Counter Rotate; Extend.

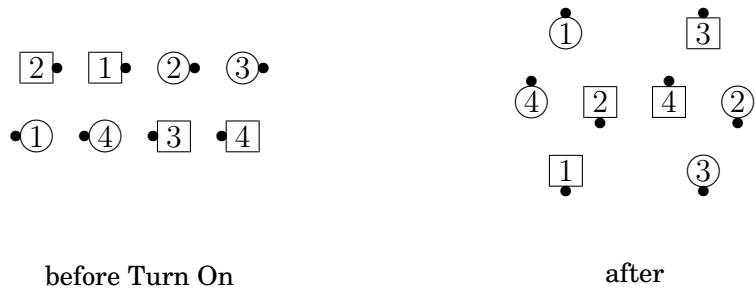

Turnover

Cast Off 3/4 and Slither. This is where Checkover gets its name.

Turntable

Centers 1/4 right and do 2 Once Removed Circulates. The ends move in (forward, backward, or sideways) and Single Rotate 1/2. Note that it's 1/2. Note also that 2 Once Removed Circulates will always take the centers out to the outside, no matter what their facing directions.



On the call "Centers go as you are, Turntable", the initial 1/4 right is omitted.

Veer and Turn <M/4> x <N/4>

This must be preceded by a call that sets up a natural veering direction. There is no default direction.

Veer Left or Right in the appropriate direction. Then the Centers Cast Off by the first fraction, while the ends turn the second number of quarters, starting with a turn inward.

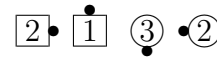
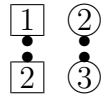

before Veer and Turn
1/2 x 1/4, after
right-handed Recycle

after

Veering <anything>

Veer in the appropriate direction, as in Veer and Turn, and then **finish** the <anything> call. See [Rolling <anything>](#), page 120.

Vertical Turn and Deal

Vertical 1/2 Tag, then those who turned do a “delayed Roll”, the same as on plain Turn and Deal.

It is common for some people to be able to Roll while others cannot.

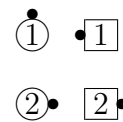
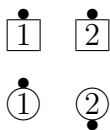

before Vertical Turn and Deal

after

Walk Out to a Column

From waves: Those looking out do a Once Removed Single Wheel with each other and step forward to become the centers of the resulting column. The trailing centers walk straight ahead to become #1 of the column. The trailing end walks forward and folds to become #4.

The trailers' part can be thought of as an All 8 Circulate and a Step and Fold.

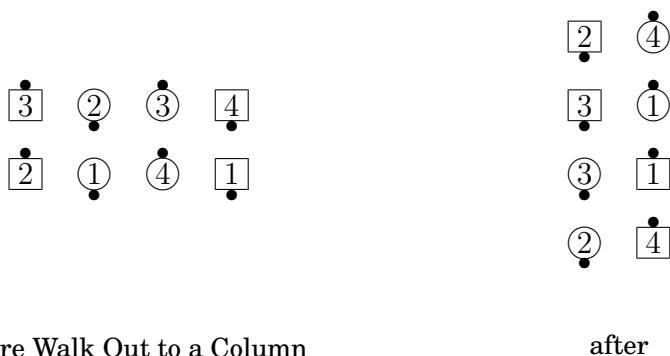

The Single Wheel is always a normal right-handed one. The people doing it typically get each other's attention and tap hands before doing it.

Walk the [Cross] Clover

Often from a Trade by: outsides Cloverleaf while the centers Touch 1/4 and then Walk and Dodge. On Walk the Cross Clover, the outsides Cross Cloverleaf.

If the centers are already in a wave, they simply Hinge and Walk and Dodge.



If the setup is parallel waves, all Extend and then proceed as above.

Walk the Plank, <anything> the Plank

The Plank is Walk and Dodge in the center while the end looking out runs around the other end. It is commonly used as a suffix. The "Walk" in "Walk the Plank" is a Circulate, usually a column Circulate.

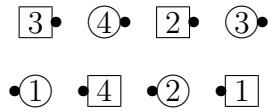

before Walk the Plank

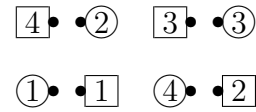

after

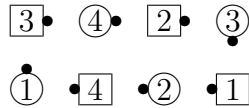

before Finally Split Phantom
Boxes Walk the Plank

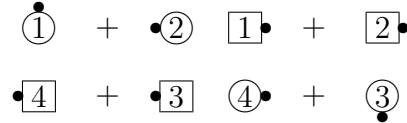

after

Wheel Fan and Cross Thru

Wheel Fan Thru, and then Half Sashay.

Wheel to a Diamond / Interlocked Diamond, Hourglass, Z

Leads Wheel Around (as in Wheel the Ocean). Then the belles start to cross, taking right hands in the center, while the beaux Quarter Left.

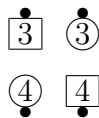

before Wheel to a Diamond

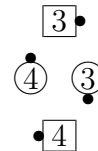

after

For the other setups, see the discussion of <ATC> to a Diamond.

Wheel to a Line

As couples Single Turn to a Line. That is, any lead couple goes right and any trailing couple goes left.

[Cross] [Criss Cross] Wind the Bobbin

On a Cross Wind the Bobbin, the leaders of each box Trail Off instead of Peeling Off before doing their two Circulates. Even though it's awkward in the center. This is sometimes called Trail the Bobbin.

On a Criss Cross Wind the Bobbin, in addition to the above, the trailers take opposite hands before their Cast Off 3/4.

Who's On First

This is used to begin an unsymmetrical sequence. From a squared set, the designated couple walks straight across to the opposite position and does a U-Turn Back. That opposite couple slides apart from each other, and each person goes into the next position in the squared set, all the way around to the spots vacated by the original designated couple.

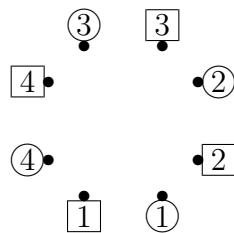

before Who's on First,
#1 Couple Go

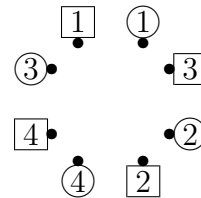

finished

This call is usually delivered as shown above, but might just have a base number indicated, as in "Who's On Second".

Wipe Out

From waves or 2-faced lines: Ends do their part of a Swing and Slip. Centers Scoot Back and Spread.

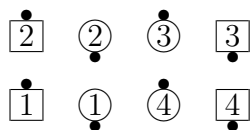

before Wipe Out

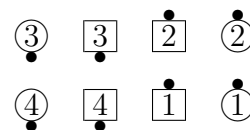

after

But beware: The above is sort of a cheat. The ends' initial part is actually a phantom run, not a “do your part, swing”, and that part is therefore not subject to Generous, Stingy, or Yoyo. These concepts, applied to the ends, will act on the second part only. They may not be applied to the centers.

With Finesse

From columns or magic columns: Ends Cast Off 3/4 and Spread to become ends of each half of the resulting tidal wave. The centers do a Zing, slightly wider than usual to keep out of the way of the others. They then step into the space, taking their “cold hand” with each other—the hand other than the one they had at the start of the call.

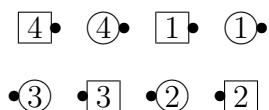

before With Finesse



after

when done from a column of 6, the ends Cast Off 3/4 and Spread as before. The centers roll outward and **back** and step into the space.

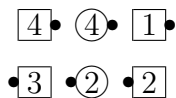

before With Finesse

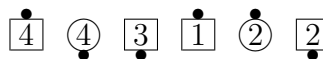

after

With Magnetism

If your (lateral) partner is the same gender as you, Quarter Out. If different, Quarter In. If people are T-boned, everyone makes their own evaluation.

You All

Centers Hinge while the ends U-Turn Back.



before You All

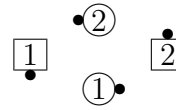

after

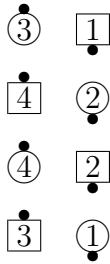

before You All

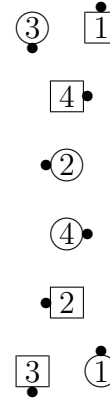

after

This is supposed to be a 4-person call (notwithstanding the immediately preceding diagram), so, when done from a tidal wave, the “centers” are the centers of each side.

<anyone> **Zing** <N>

The designated people 3/4 Stable Zoom back behind N people, each of whom moves ahead and Quarters In.

Zip the Top

Lockit and the centers U-Turn Back toward each other.

<anyone> **Zoom** <N>

The designated people Zoom back behind N people, each of whom moves ahead.

Zoom Roll Circulate

This is like Out Roll Circulate, but the Out Roller Zooms back.

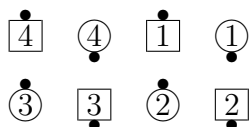

before Zoom Roll Circulate

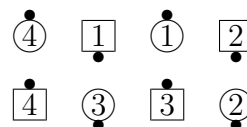

after

Zoom Roll to a Diamond, Zoom Roll to a Wave

See [In Roll To a Diamond](#), page 85, or [In Roll To a Wave](#), page 86.